



MACCHINE PER PNEUMATICI E PER I PROCESSI DI RICOSTRUZIONE
EQUIPMENT FOR THE TYRE AND RETREADING INDUSTRIES

matteuzzi srl
Via Serra 1/E - 3
40012 Calderara di Reno - Bologna - ITALY
Tel. +39 - 051726351
Fax +39 - 051726283
matteuzzi@matteuzzi-srl.com
www.matteuzzi-srl.com

OPERATION AND MAINTENANCE MANUAL



RAS 405

PRECURED TREAD BUILDING AND STITCHING MACHINE FOR
TRUCK TYRES



First printed on 24 April 2007

Revision: 03 / 17.06.2020

machine type	RAS 405 <i>Precured tread building and stitching machine for truck tyres</i>
year of manufacture	2021
serial no.	MAT - 21117
manufacturer	MATTEUZZI SRL Via Serra, 1/E – 3 40012 CALDERARA DI RENO BOLOGNA - Italy
importer	

This manual is an integral part of the machine. It must be kept close to hand when using the machine and must be available for transfer to other users if necessary.

CONTENTS

1. INTRODUCTION	6
1.1. GENERAL SAFETY INSTRUCTIONS	6
1.2. LIMITED LIABILITY	8
1.3. DEFINITIONS.....	9
1.4. WARRANTY	10
1.5. PERSONNEL SELECTION AND REQUIREMENTS.....	10
2. PRELIMINARY MACHINE INFORMATION.....	11
2.1. GENERAL DESCRIPTION.....	11
2.2. USE.....	12
2.2.1. PROHIBITED USE.....	12
2.2.2. TYRE CASING AND TREAD SIZES	12
2.2.3. INSTRUCTIONS ON THE TYRE	13
2.2.4. TYRE INFLATION PRESSURE.....	13
2.3. IDENTIFICATION PLATE	14
2.4. RESIDUAL RISKS.....	15
2.4.1. MACHINE HANDLING	15
2.4.3. MACHINE IN OPERATION	16
2.4.4. MACHINE MAINTENANCE	18
2.4.5. NOTICES ON THE MACHINE	20
2.5. TECHNICAL DATA.....	22
2.5.1. WEIGHT AND DIMENSIONS OF THE MACHINE IN SERVICE	22
2.5.2. ELECTRICAL POWER SUPPLY	24
2.5.3. COMPRESSED AIR SUPPLY.....	25
2.6. AMBIENT AND OPERATING CONDITIONS	26
2.6.1. OPERATING ENVIRONMENT.....	26
2.6.2. AERIAL NOISE EMISSION	26
2.7. OPERATING TOOLS.....	27
2.7.1. TREAD CUTTER BLADE.....	27
3. MACHINE HANDLING, POSITIONING AND INSTALLATION	29
3.1. PACKED MACHINE HANDLING	29
3.2. MACHINE POSITIONING.....	31
4. CONNECTION TO POWER SUPPLIES	32
4.1. WARNINGS.....	32

CONTENTS

4.2.	COMPRESSED AIR.....	33
4.3.	ELECTRICAL POWER	34
5.	MACHINE USE.....	36
5.1.	WARNINGS.....	36
5.2.	SAFETY DEVICES AND FUNCTIONS	37
5.2.1.	EMERGENCY STOPS PUSH-BUTTONS	37
5.3.	ELECTRICAL CONTROLS	38
5.3.1.	BUILDING ZONE CONTROL PANEL.....	38
5.3.2.	STITCHING ZONE CONTROL PANEL	41
5.3.3.	POLY ZONE CONTROL PANEL	42
5.3.4.	CUTTING ZONE BI-MANUAL CONTROLS.....	43
5.3.5.	ELECTRICAL CABINET	43
5.3.6.	PEDAL CONTROLS.....	43
5.4.	PNEUMATIC CONTROLS	44
5.5.	COMPRESSED AIR CONTROL DEVICES.....	45
5.6.	MECHANICAL ADJUSTMENTS.....	48
5.6.1.	CHANGING THE RIM OF THE EXPANDING HUB.....	48
5.7.	OPERATOR WORK STATION	49
5.8.	OPERATION	50
5.8.1.	MACHINE EMPTY RESTART.....	50
5.8.2.	INFLATING AND DEFLATING THE TYRE	50
5.8.3.	APPLYING THE CUSHION GUM ON THE BUFFED TYRE	51
5.8.4.	PRECURED TREAD ROLL LOADING AND FEEDING	51
5.8.5.	TREAD APPLICATION AND STITCHING CYCLE	52
5.8.6.	HOW TO LEAVE THE MACHINE AT THE END OF THE WORKSHIFT	52
6.	MAINTENANCE	53
6.1.	SAFETY RULES FOR MAINTENANCE AND REPAIRS	53
6.2.	RULES REGARDING WORK ON ELECTRICAL COMPONENTS	53
6.3.	MAINTENANCE OPERATIONS.....	54
6.3.1.	DAILY MAINTENANCE.....	54
6.3.2.	MONTHLY MAINTENANCE	55
6.3.3.	QUARTERLY MAINTENANCE.....	55
6.3.3.1.	Lubrication	55
6.3.3.2.	Gearboxes	58
6.3.4.	SEMIANNUAL MAINTENANCE	58
6.4.	RETOOLING	59

CONTENTS

6.4.1.	CHANGING THE BLADE IN THE TREAD CUTTER	59
6.5.	ACCESSORIES PROVIDED	60
6.6.	ORDERING SPARE PARTS.....	60
7.	DECOMMISSIONING	61
7.1.	STOPPING THE MACHINE	61
7.2.	DISASSEMBLY AND DISPOSING	61
7.3.	DISPOSING AND SCRAPPING	61
8.	LIST OF ANNEXES.....	62

INTRODUCTION

1. INTRODUCTION

1.1. GENERAL SAFETY INSTRUCTIONS

1. This manual provides the user with the instructions needed to ensure safe and correct use of the machine and to perform running maintenance operations on it. All personnel involved in the transportation, installation, commissioning, operation, maintenance and repair of the machine and its accessories must have read and properly understood:
 - the operating instructions,
 - the safety rules,
 - the warnings contained in the individual chapters and paragraphs.
2. It is forbidden for two or more persons to use the machine simultaneously, whether for operating or to carry out maintenance. The operator must be properly trained to use the machine, to evaluate the characteristics and condition of the casing to be processed and to perform, when necessary, the adjustments and settings as dictated by the type of job to be done. Persons under the influence of drugs, alcohol or medicines that impair the speed of their reflex reactions must not be allowed to engage in the installation, operation, retooling and maintenance of the machine.
3. Failure to observe the warnings contained in this manual might cause personal injury and even death. The manual must be accompanied by the company's specific rules, including supervisory and reporting duties, regarding work organization, work cycles, personnel appointed to the various tasks and other matters.
4. The user must check that the personnel perform their tasks with full knowledge and awareness of the safety rules and hazards, and that they follow the instructions contained in this manual. The user must also make sure that the machine is always in perfect working order.
5. The machine may only be used in perfect working order and it must be used by a single trained operative, in compliance with the prevailing safety and accident-prevention regulations. This provision includes observance of the operating and maintenance instructions contained in this manual.
6. Warnings and danger signs in the form of plates, stickers and marks fitted to the machine must be scrupulously observed. These plates, stickers and marks must not be removed and must be legible at all times.
7. Do not cover the cooling grilles on the electrical cabinet.

INTRODUCTION

8. It is forbidden to disconnect or modify the safety devices.
9. Cut off the electrical and pneumatic power supply connections and discharge any remaining air before carrying out any cleaning, retooling or maintenance operations.
10. Power up the machine to the voltage specified on the plate and set up an appropriate connection board in accordance with prevailing standards.
11. Cut off the electrical and pneumatic connections and call up the customer service when:
 - The electrical and electronic parts of the machine have been exposed to rain or water.
 - The machine does not function properly, even though the instructions are followed.
 - The machine has been damaged during transportation or handling.
 - The machine exhibits a marked deterioration with respect to its normal level of performance.



WORK SAFETY WARNING SIGN. In the following instructions this symbol appears next to warnings describing situations which, when the machine is in operation, pose a serious risk of injury. You must always observe these warnings and work with particular care and attention. Same warnings must be notified to all the persons assigned to do work on the machine.

In addition to the specific warnings, you must also take account of the general safety rules.

INTRODUCTION

1.2. LIMITED LIABILITY

The information, data and instructions contained in this manual are current at the time of printing and are based on our most up-to-date technical knowledge.

We shall make good any defects and omissions under the warranty obligations undertaken at the time of the order, but shall not satisfy any further claim. Demands for compensation, on whatever legal grounds they are made, shall not be considered.

The translations from the Italian are made with due care and diligence, but with the usual provisos. The only text forming the basis for interpretation is the original version in Italian which can be obtained on demand.

The manufacturer disclaims all liability for malfunctions or inefficiencies caused by:

improper use, negligence, non-maintenance or incorrect maintenance, incorrect manoeuvres, incorrect electrical or pneumatic power supply, omission of required adjustments, tampering or modifications not authorized in writing to mechanical, pneumatic, electrical, electronic parts or software programs.

Furthermore, the manufacturer accepts no responsibility in the event that wire or electrode welding jobs are carried out on any part of the machine or even on other machines connected to the same mains power supply, unless the manufacturer has been contacted in advance and the appropriate precautions agreed and implemented.

INTRODUCTION

1.3. DEFINITIONS

User. Denotes the party (business/firm) which uses and employs the machine and assigns suitably trained personnel to operate it.

Operator. Denotes the person instructed by the user to perform specific operations connected with the use of the machine, including the necessary cleaning, checks and visual inspections.

Trained personnel. This term denotes an individual who has received instruction and training both on the tasks assigned to him/her and on any dangers occasioned by improper use. The said individual is also well informed and has demonstrated his or her knowledge regarding the necessary safety devices, protective measures, relevant regulations, health and safety rules and work conditions.

Mechanical maintenance technician. This term denotes an individual who is in charge of mechanical adjustments, maintenance and repairing.

Electrical maintenance technician. This term denotes an individual who is in charge of electrical adjustments, maintenance and repairing.

Dangerous area. Any area inside or close to the machine, where the presence of a person implies a risk to the health and safety of that person.

Exposed person. Any person totally or partially inside a dangerous area.

Danger. Any cause of possible health and safety damage.

Risk. The product between the probability that an event could happen and the seriousness of injures or damages to health and safety it can cause.

Protections. Safety measures that protect operators from dangers that cannot be eliminated or mitigated through design only.

Shelter. A protection that consists of a physical barrier.

	<p>Tyre casings and tyres may generically be described as <i>tyres</i> in the descriptions provided in this manual, when no more specific mention is required.</p>
--	---

INTRODUCTION

1.4. WARRANTY

This manual contains all the information, rules and standards to be observed. Therefore, it must be read carefully before starting up the machine.

MATTEUZZI SRL may not be held liable for any damage or operating abnormalities resulting from failure to observe the service instructions.

The machine's wear parts are not covered by the warranty. Any claims under warranty must be reported immediately, as soon as the defect is identified, and the machine's serial number must also be specified.

The warranty lapses in the following cases:

- improper use,
- use of work equipment that is not allowed,
- installation and connection of electrical cables performed incorrectly and not in conformity with prevailing regulations,
- use of non-original spare parts or accessories.
- modifications made without the permission of MATTEUZZI SRL and, in particular, modifications which include electrode or wire welding.

1.5. PERSONNEL SELECTION AND REQUIREMENTS

With respect to the operation or maintenance of the machine to be performed independently, the user may only assign operators who:

- are over 18 years of age;
- have suitable physical and mental abilities;
- have been trained in the use or maintenance of the machine and have then demonstrated their competence. The training must include teaching of the necessary theoretical concepts regarding the machine and the characteristics of tyre casings, and it must also provide sufficient opportunity for the trainees to carry out practical trials and acquire the ability to identify abnormalities that might threaten work safety;
- can be relied upon to perform competently the operations assigned to them.

The user must clearly define the tasks and duties of the personnel with regard to operation, maintenance and repairs.

PRELIMINARY MACHINE INFORMATION

2. PRELIMINARY MACHINE INFORMATION

2.1. GENERAL DESCRIPTION

The machine is designed to build and stitch the precured tread and cushion gum on buffed or buffed and cemented casings of bus, truck and light transport vehicle tyres.

These operations may only be performed on tyre casings that have already been inspected, cleaned to remove foreign objects, repaired and buffed.

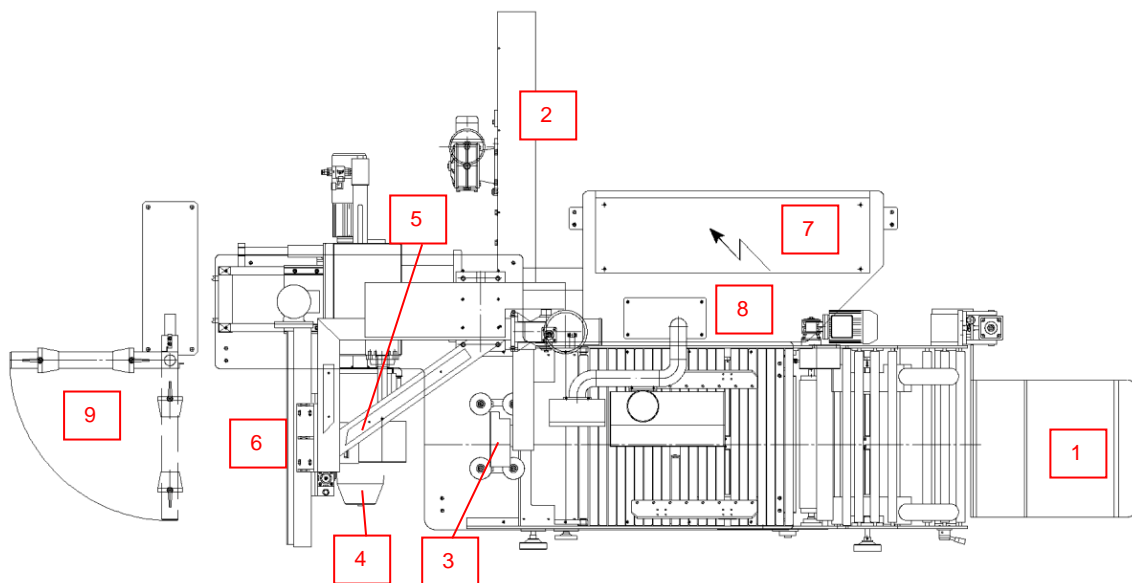

Figure 1: general description

1. Tread lift
2. Precured tread cutter
3. Tread positioner
4. Expandable hub
5. Tread presser
6. Building and stitching zone
7. Electrical cabinet
8. Control panel
9. Poly support

PRELIMINARY MACHINE INFORMATION

2.2. USE

The machine is designed to build and stitch the precured tread and cushion gum on buffed or buffed and cemented casings of bus, truck and light transport vehicle tyres.

These operations may only be performed on tyre casings that have already been inspected, cleaned to remove foreign objects, repaired and buffed.

2.2.1. PROHIBITED USE

It is forbidden to use the machine for any purpose other than the ones described at par.2.2.

It is also forbidden to use the machine to process:

- tyre casings filled with dirt, earth or other substances,
- tyre casings containing water,
- tyre casings showing marked mechanical damage (cuts, raised belts, deformed beads, etc.),
- solid (non-inflatable) tyre casings,
- tyre casings exceeding the permitted weight,
- unbuffed tyre casings that could cause intermittent impact and vibrations dangerous for the operator and for machine mechanisms.

2.2.2. TYRE CASING AND TREAD SIZES

The standard machine is designed to process casings and tread strips of the following sizes:

	<i>MINIMUM</i>	<i>MAXIMUM</i>
<i>External diameter</i>	711 mm (28")	1193 mm (47")
<i>Bead diameter</i>	14"	24.5"
<i>Tyre casing weight</i>	---	110 kg (243 lbs)
<i>Tread width</i>	140 mm (5 1/2")	410 mm (16.5")
<i>Tread thickness</i>	---	28 mm (1 1/8")

Different limits are possible when requested by the user at the time of the order.

PRELIMINARY MACHINE INFORMATION

2.2.3. INSTRUCTIONS ON THE TYRE

Any instructions stamped on the sidewall of the casing by the tyre manufacturer must be followed.

2.2.4. TYRE INFLATION PRESSURE

MAXIMUM PRESSURE: 2 bar (30 PSI)

PRELIMINARY MACHINE INFORMATION

2.3. IDENTIFICATION PLATE



Figure 2: CE identification plate

The identification plate is fitted on the machine frame.

The following data are reported on the identification plate:

- CE marking (when applicable)
- Manufacturer name and address
- Machine model
- Serial number
- Weight
- Year of manufacture
- Electrical data

When contacting the machine manufacturer, in order to request information or ordering spare parts, the following data must always be specified:

- Machine model
- Serial number
- Year of manufacture





PRELIMINARY MACHINE INFORMATION

2.4. RESIDUAL RISKS

	<p>Warning and danger notices in the form of plates, adhesives and marks applied to the machine must be strictly observed. They must not be removed and must be legible and easy to read at all times.</p>
---	---

2.4.1. MACHINE HANDLING







<p><u>Risks:</u></p>	
<p>During machine handling, the operator may crush his hands, feet or other body parts.</p>	

<p><u>Personal protective equipment:</u></p>	
<p>Gloves</p>	
<p>Protective footwear</p>	
<p>Hard hat</p>	
<p>Work apparel</p>	

<p><u>Safety procedures:</u></p>	
<p>Use handling devices with adequate lifting capacity.</p>	<p>--</p>
<p>Operate on flat surfaces.</p>	<p>--</p>
<p>Always check the proper fastening of the parts to be lifted.</p>	<p>--</p>
<p>Strictly follow the instructions reported in the Operation and Maintenance Manual.</p>	<p>--</p>

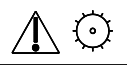
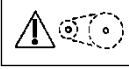

PRELIMINARY MACHINE INFORMATION

2.4.3. MACHINE IN OPERATION

<u>Risks:</u>	
Cutting risk due to the rotary cutter.	
MECHANICAL PARTS IN MOVEMENT These plates are present on the protections covering dangerous moving parts (gears, belts, tools, etc.) The protections can be removed for maintenance reasons by trained personnel only after cutting off the electrical power and compressed air supplies.	  
MIND YOUR HANDS! The operator must pay attention to machine parts that may pose a risk of crushing, such as: <ul style="list-style-type: none"> o roller guides, o sectors of expanding hub, o building and stitching groups. 	
Electrocution due to contact with electrical parts.	
Entanglement due to parts in movement.	



Crushing, cutting and entanglement risks are present also when the machine is not performing a cycle, due to compressed air in the pneumatic circuit.

<u>Personal protective equipment:</u>	
Work apparel without loose or frayed elements that may be caught in rotating or moving parts	
The operator must wear gloves to protect his hands from mechanical injury when handling the casing, since it might have exposed steel belts or there may be nails or other sharp objects embedded in it that were not removed during inspection.	

PRELIMINARY MACHINE INFORMATION

Personal protective equipment:

The operator must wear protective footwear.



In particular conditions it may be necessary to wear other personal protective equipment suitable for the operation performed.

--

Safety procedures:

Keep the area surrounding the machine clean, free from obstacles and objects that may make it slippery.

--

Make sure that only authorized personnel is in the working area.



Do not remove safety devices.



Strictly follow the instructions reported in the Operation and Maintenance Manual.

--

Do not wear loose long hair.

--

Do not wear jewellery.

--

Do not weld (It is forbidden to carry out electrode or wire welding on any part of the machine, on other machines in the vicinity or on machines connected to the same mains power supply. Permanent damage may be done to the computer and equipment connected to it and your warranty voided. If necessary, contact Matteuzzi srl to establish the required precautions.).







Do not use water to extinguish fire.





PRELIMINARY MACHINE INFORMATION

2.4.4. MACHINE MAINTENANCE

<u>Risks:</u>	
Hands and feet crushing due to sudden falling of machine parts or tools during retooling.	
Electrocution due to contact with electrical parts.	

<u>Personal protective equipment:</u>	
The operator must wear gloves.	
The operator must wear protective footwear.	
Personal protective equipment that may be necessary for the specific maintenance operations.	--

<u>Safety procedures:</u>	
Maintenance operations can be performed only by qualified personnel.	
To perform maintenance operations, follow this general procedure: cut off all machine power supplies, perform the necessary maintenance, reconnect the machine to the power supplies, check the safety conditions of the machine.	
Strictly follow only the maintenance interventions reported in the Operation and Maintenance Manual.	--
Do not grease parts in motion.	

PRELIMINARY MACHINE INFORMATION

Safety procedures:

Do not weld (It is forbidden to carry out electrode or wire welding on any part of the machine, on other machines in the vicinity or on machines connected to the same mains power supply. Permanent damage may be done to the computer and equipment connected to it and your warranty voided. If necessary, contact Matteuzzi srl to establish the required precautions.).



Do not use water to extinguish fire.



WARNING!



High voltage is available inside the electrical box even after supply cut off. Wait at least 5 minutes before opening the electrical cabinet or touching any other electrical device.



PRELIMINARY MACHINE INFORMATION**2.4.5. NOTICES ON THE MACHINE**

Warning and danger notices in the form of plates, adhesives and marks applied to the machine must be strictly observed. They must not be removed and must be legible and easy to read at all times.

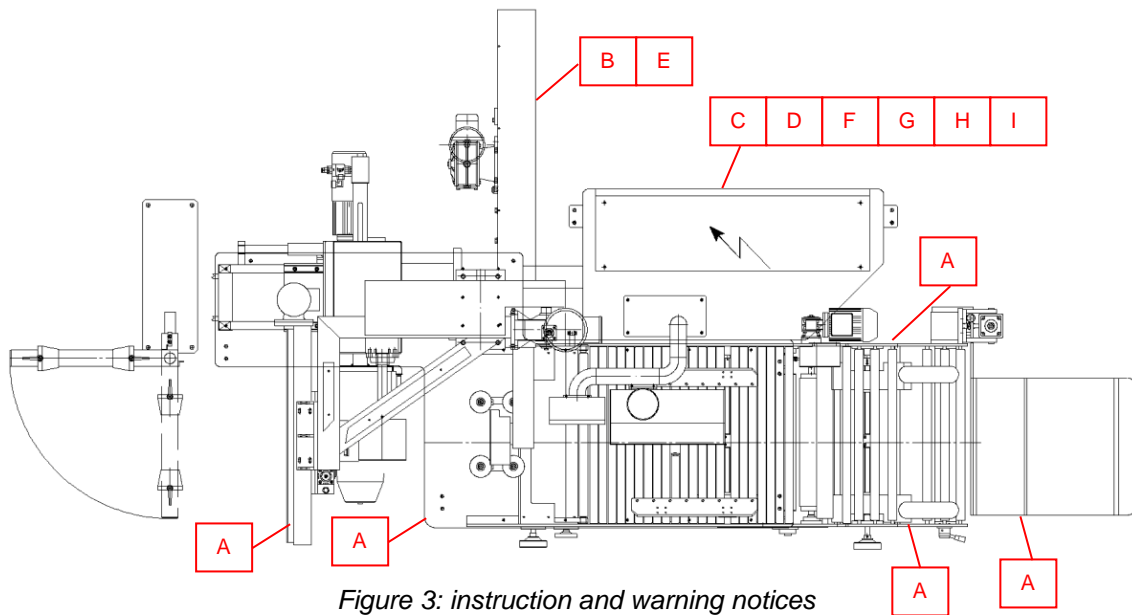

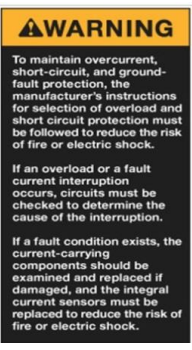

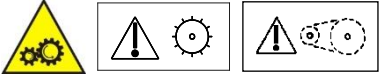





Figure 3: instruction and warning notices

PRELIMINARY MACHINE INFORMATION

REF.	NOTICES ON THE MACHINE	INSTRUCTIONS FOR OPERATOR
A		HAND CRUSHING RISK
B		CUTTING RISK DUE TO THE ROTARY CUTTER.
C	 <p>WARNING To maintain overcurrent, short-circuit, and ground-fault protection, the manufacturer's instructions for selection of overload and short circuit protection must be followed to reduce the risk of fire or electric shock. If an overload or a fault current interruption occurs, circuits must be checked to determine the cause of the interruption. If a fault condition exists, the current-carrying components should be examined and replaced if damaged, and the integral current sensors must be replaced to reduce the risk of fire or electric shock.</p>	<p>WARNING</p> <p>To maintain overcurrent, short-circuit and ground-fault protection, the manufacturer's instructions for selection of overload and short circuit protection must be followed to reduce the risk of fire or electric shock.</p> <p>If an overload or a fault current interruption occurs, circuits must be checked to determine the cause of the interruption.</p> <p>If a fault condition exists, the current-carrying components should be replaced if damaged, and the integral current sensors must be replaced to reduce the risk of fire or electric shock.</p>
D		<p>WARNING</p> <p>ARC FLASH AND SHOCK HAZARD Appropriate personal protection equipment required.</p>
E		MECHANICAL PARTS IN MOVEMENT
F		<p>DANGER</p> <p>Hazardous voltage. Disconnect power before servicing or cleaning.</p>
G		<p>CAUTION</p> <p>Risk of electric shock. More than one disconnect switch may be required to de-energize the equipment before servicing.</p>
H		<p>DANGER</p> <p>Risk of electric shock. Yellow wires inside the panel remain energized when the main switch is in the off position. To service this circuits, shut off the equipment at the main service disconnect.</p>
I		<p>HAZARDOUS VOLTAGE</p> <p>All doors must be closed before energizing the panel.</p>

PRELIMINARY MACHINE INFORMATION

2.5. TECHNICAL DATA

2.5.1. WEIGHT AND DIMENSIONS OF THE MACHINE IN SERVICE

DIMENSIONS OF THE MACHINE IN SERVICE	3400 x 1975 x 2137 (h) mm 134" x 78" x 84" (h)
WEIGHT	980 kg 2161 lbs
MACHINE BASE	1,8 m ² 2.15 sq. yd

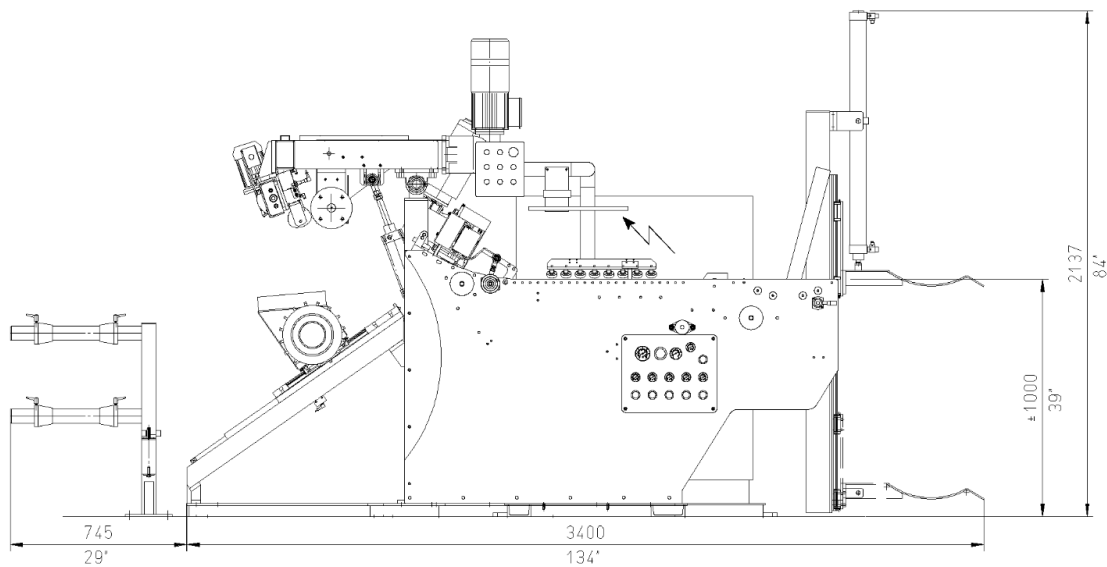

Figure 4: dimensions of the machine in service

PRELIMINARY MACHINE INFORMATION

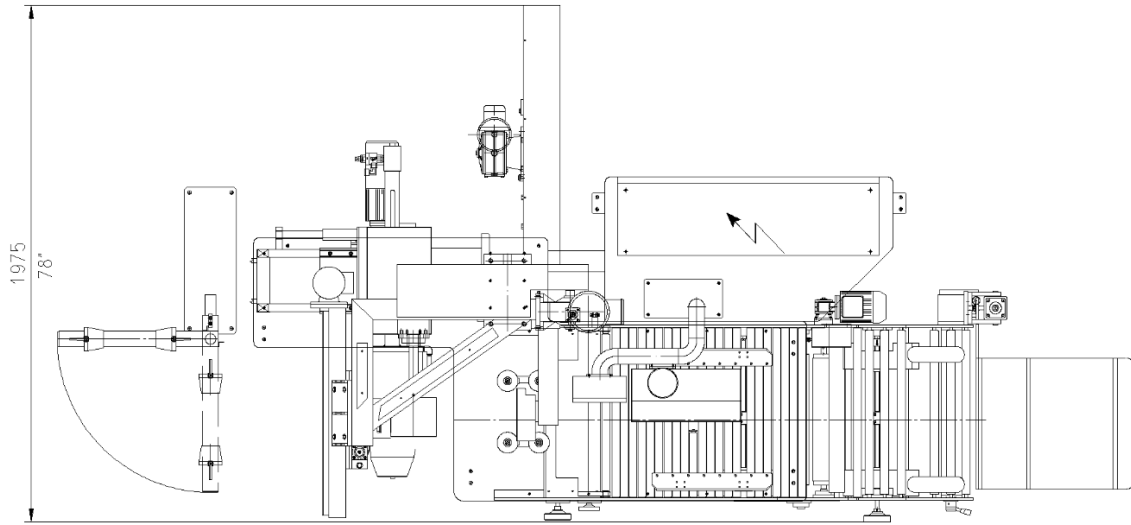

Figure 5: dimensions of the machine in service

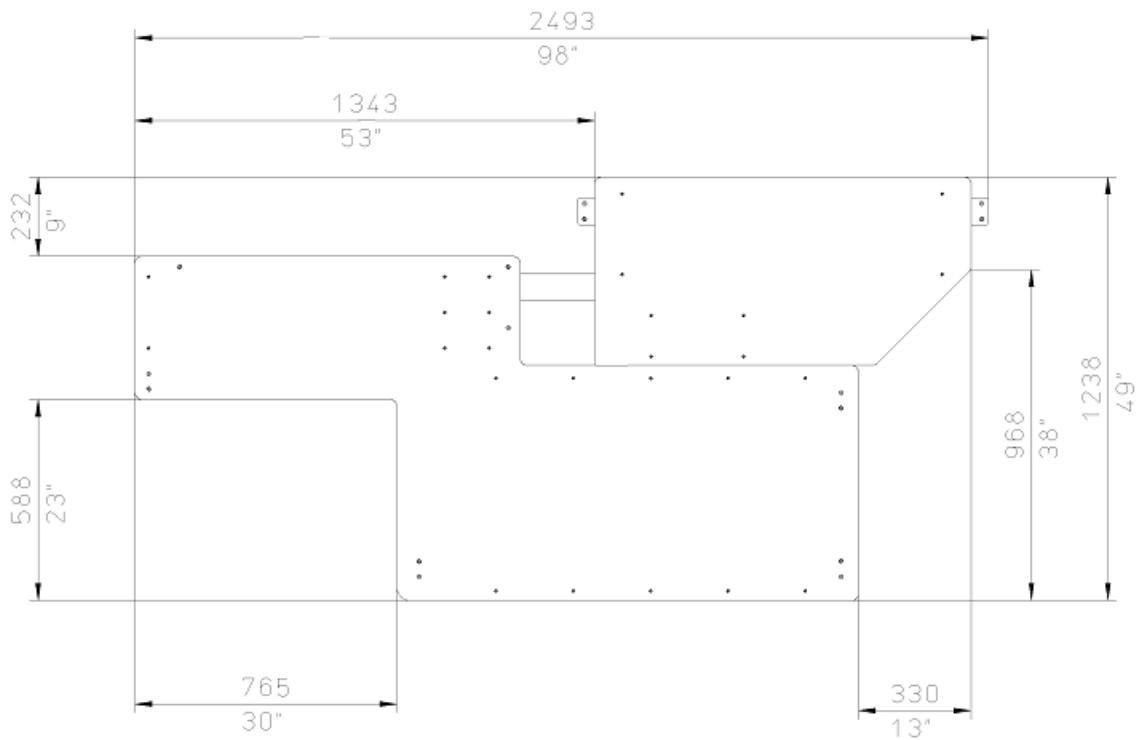

Figure 6: machine base

PRELIMINARY MACHINE INFORMATION

2.5.2. ELECTRICAL POWER SUPPLY

Total installed power	5,7 kW
Rated output	7 Ampere
Voltage	The machine is designed for connection to the following type of power supply: 480 Volt, 3-phases, 60 Hz

The power supply line must be stable and foolproof.

The configuration of the system upstream of the machine must contain protection devices suitable to the data reported above.

The voltage, frequency, system and rated current of the machine are also indicated on the notice applied to the door of the electrical cabinet.

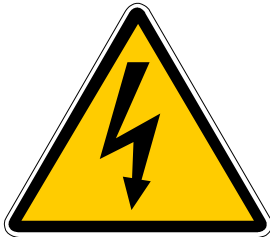

ONLY A QUALIFIED ELECTRICAL MAINTENANCE ENGINEER MAY ACCESS THE ELECTRICAL CABINET AND LIVE CIRCUIT.

CONNECTION TO THE ELECTRICAL MAINS MUST BE MADE BY A QUALIFIED ELECTRICAL MAINTENANCE TECHNICIAN IN ACCORDANCE WITH CURRENT ACCIDENT-PREVENTION REGULATIONS.

PRELIMINARY MACHINE INFORMATION

2.5.3. COMPRESSED AIR SUPPLY

Compressed air supply	8 bar (120 psi)
Compressed air absorption	700 NI/cycle (25 cu ft/cycle)

Compressed air is supplied to the machine's circuit through a lockable inlet valve connected to a filter-reducer unit. The inlet valve provides a quick coupling.

To cut off compressed air supply to the machine, during operations requiring this precaution, the maintenance technician shall close and lock the actuator of the lockable inlet valve. The locking key must be kept by the maintenance technician in a safe place.

PRELIMINARY MACHINE INFORMATION

2.6. AMBIENT AND OPERATING CONDITIONS

2.6.1. OPERATING ENVIRONMENT

	MIN	MAX
Temperature	5° C	40° C
Relative humidity	30%	90%

Lighting	<p>>300 lux required in the operator area.</p> <p>The machine operates in a closed industrial environment in the presence of people at work and the lighting provided in the workplace under prevailing local regulations is deemed sufficient.</p>
----------	--

2.6.2. AERIAL NOISE EMISSION

The following parameters were measured at the operator workstation during a working cycle of a new and properly serviced machine:

- LA(eq) [dB], equivalent continuous A-weighted sound pressure level.

Measurements were made according to method UNI EN ISO 3746:2011 – determination of occupational noise exposure.

MEASUREMENT RESULTS

LA(eq) = 78,5 dB (A) (average value).

PRELIMINARY MACHINE INFORMATION

2.7. OPERATING TOOLS

2.7.1. TREAD CUTTER BLADE

Installed on the tread cutter there is a circular blade with the following characteristics:

OPTION A: 6" BLADE

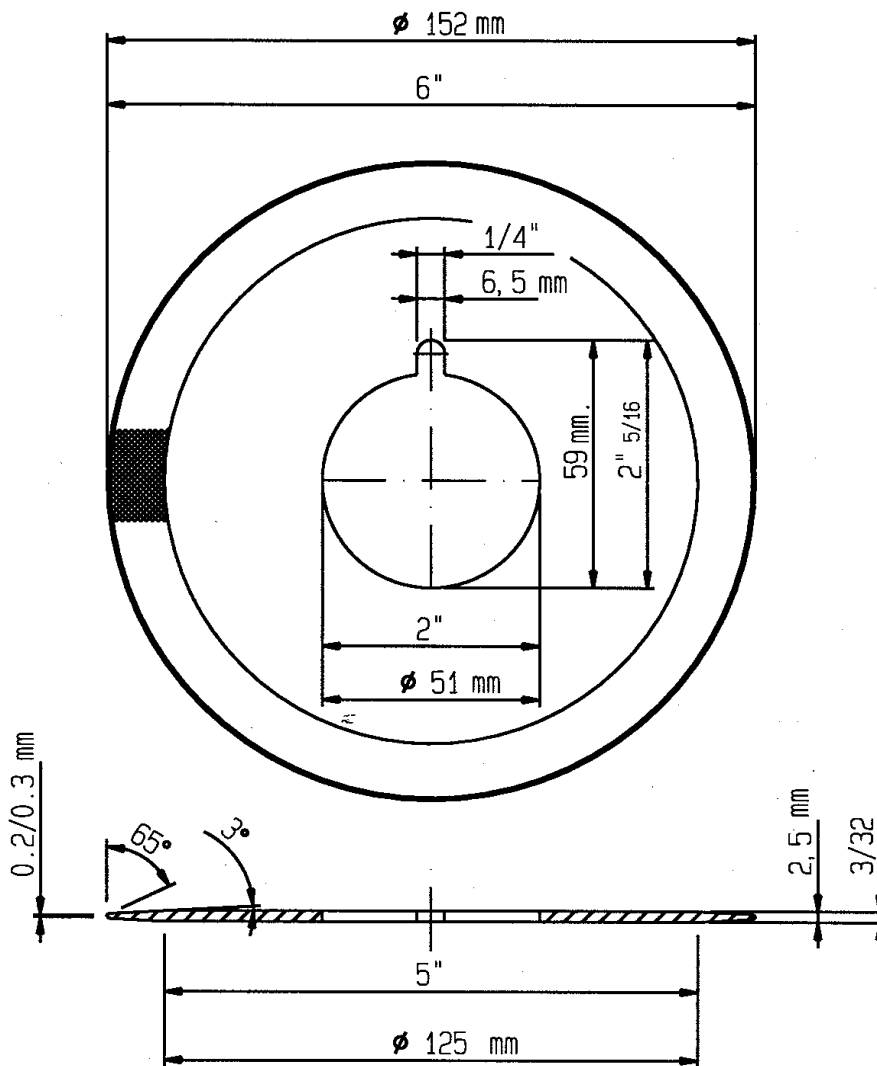

Figure 7: circular blade

PRELIMINARY MACHINE INFORMATION

OPTION B: 7" BLADE

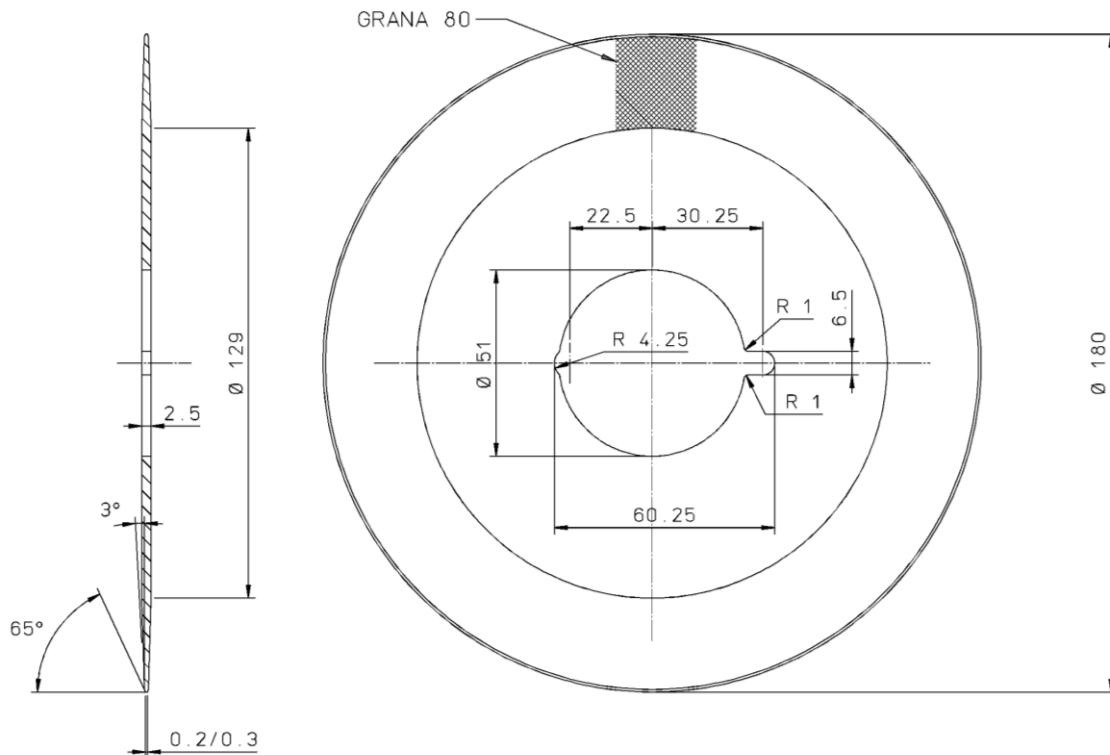

Figure 8: circular blade

Use a tool with the same characteristics when replacing the blade.

The type and characteristics of the precured tread being used may consume the circular blade more or less rapidly. Bear in mind that worn blades diminish the quality of the cut.

It is forbidden to fit any other type of tool in place of the circular blade.

The *Retooling* chapter contains instructions on how to replace the circular blade.

MACHINE HANDLING, POSITIONING AND INSTALLATION

3. MACHINE HANDLING, POSITIONING AND INSTALLATION

3.1. PACKED MACHINE HANDLING

The machine and accessories are packed and secured to the pallets with bolts and nails in order to obtain a single rigid body, that is covered by a protective film.



Inspect each package upon receipt, and carefully make sure it has not been damaged or tampered.

ANY DAMAGE NOTICED ON THE MACHINE UPON RECEIPT MUST BE COMMUNICATED TO THE MACHINE MANUFACTURER.

The below reported operations may only be performed by trained personnel and with the use of a forklift truck with sufficient lifting capacity and fork length commensurate with the weight and dimensions of the package. Any other equipment must be considered unsuitable and dangerous.

Standard machine packing:

NET WEIGHT			
Pallet or crate	1 / 1	Machine and accessories	980 kg (2161 lbs)

Detailed information regarding actual packing are reported at shipment time in the specific packing list.

1. Use a forklift truck to load/unload the packed machine and accessories, and to transport them to the installation site.



- **The user has to choose an adequate installation site taking into consideration the space needed for tyre feeding and discharging.**
- **If necessary, the user has to install further safety devices, other than the ones supplied with the machine.**
- **The machine is designed to be used by a single operator. No other person must be able to gain access to the moving parts, which must be isolated and protected from the rest of the workplace by the user.**

MACHINE HANDLING, POSITIONING AND INSTALLATION

Pallet or crate

1 / 1

Machine and accessories



Figure 9: packed machine handling

MACHINE HANDLING, POSITIONING AND INSTALLATION

3.2. MACHINE POSITIONING

1. Check that the floor is level and able to bear the weight of the machine.
2. Lift the machine 100 mm (4") off the floor so as to remove the pallet after the fastening devices have been removed. For this purpose use ropes hooked to the parts of the machine with facility for their connection.
3. The pallet to which the machine is secured is protected by a waterproof polyethylene sheet which, if thrown away, must be disposed of properly and in accordance with local anti-pollution regulations.
4. Place in a position convenient to the operator the stand provided to support the rolls of cushion gum and protective polyethylene film. Fix it to the floor means of the relevant screws.
5. Secure the machine units to the floor using the holes provided in the base.

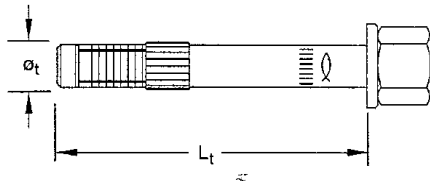
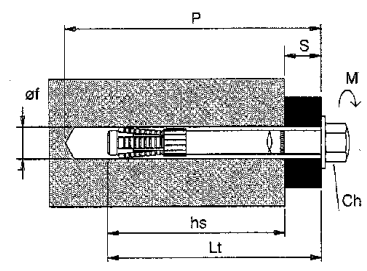

We suggest to use steel anchors suitable for fixing into solid materials. The following data refer to fixings in concrete:

anchor ext. dia. - $\varnothing t$	12 mm
anchor length - L_t	100/135 mm
anchor placing depth - h_s	≥ 70 mm
drilling nominal dia. - $\varnothing f$	12 mm
drill hole depth - P	100/135 mm

4. CONNECTION TO POWER SUPPLIES

4.1. WARNINGS



Installation of the machine must be carried out by skilled personnel. The said personnel may only proceed with the installation after having studied the contents of the specification charts, figures and the information contained in the *introduction* and in this chapter of the manual.

The machine leaves the factory after undergoing repeated testing and inspection and it will be ready for use when the installation operations described below have been correctly carried out. If any further information is required, please contact the supplier, giving extensive details on the stage of machine installation and any abnormalities encountered.

The machine installation site will be determined by the customer according to the means by which the tyres and tread strips are fed to the machine, the means by which the tyres are removed and according to workplace, production and safety-related requirements.

The installation area must be protected so that only personnel authorized by the user can gain access to it.

CONNECTION TO POWER SUPPLIES**4.2. COMPRESSED AIR**

The operations described below must be carried out by trained personnel.

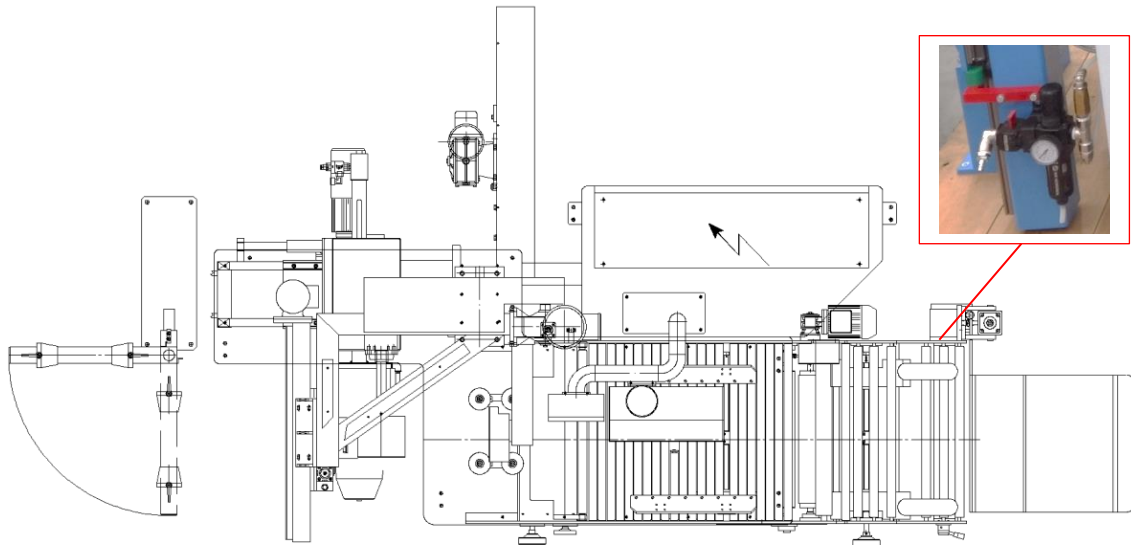

Figure 10: connection to power supplies

Supply the fitting of the lockable inlet valve connected to the filter-reducer unit with compressed air at approx. 8 bar (120 PSI). The pressure reducer is factory set to 8 bar (120 PSI) and this value must not be exceeded. The feed pressure to the machine circuit is shown on the LINE pressure gauge installed on the filter-reducer unit.



Take care during this operation as any residual air may trigger the movement of pneumatically operated parts.

CONNECTION TO POWER SUPPLIES**4.3. ELECTRICAL POWER**

The operations described below must be carried out by trained personnel.

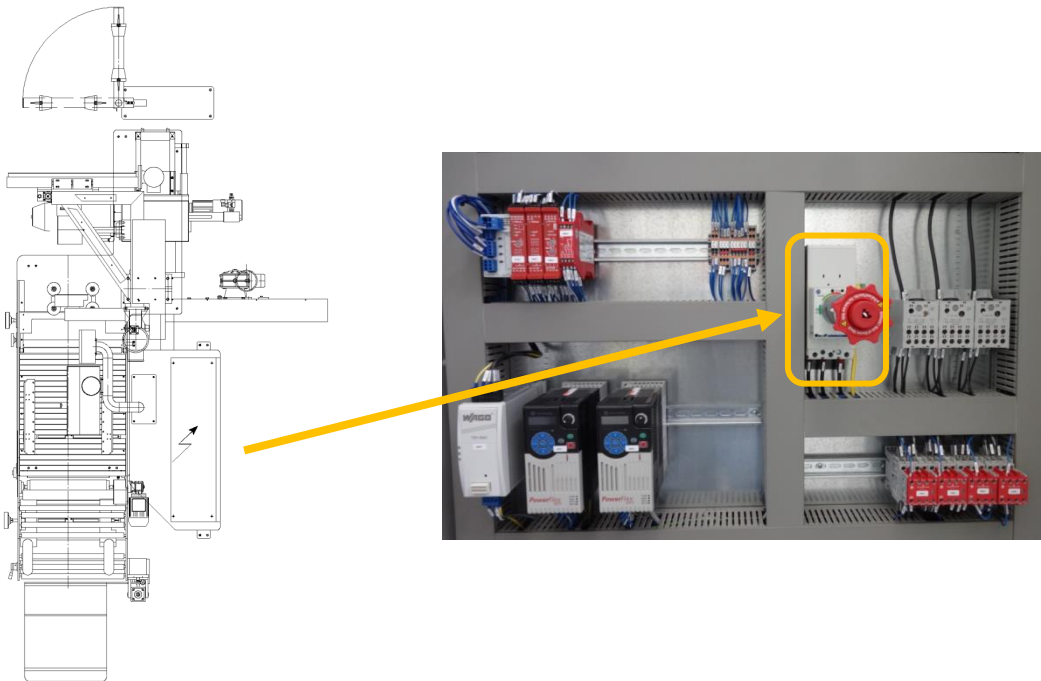

Figure 11: connection to power supplies

The electrical maintenance engineer responsible for making the electrical connection must first check that the voltage indicated on the plate applied to the machine matches the mains supply voltage.

In order to connect the machine to the electrical power supply, proceed as follows.

1. Make sure the machine is correctly connected to compressed air and its pneumatic circuit has been powered up.
2. Open the doors to the electrical cabinet and power up the terminal strip L1, L2, L3 + earth with a three-phase electrical current.
3. Close the doors of the electrical cabinet and set the MAINS SWITCH to I/ON. The LINE pilot lamp on the stitching unit control panel switches ON.
4. Before proceeding with any other operation, check that the connection has been made in phase as follows.
 - a. Release, if necessary, the EMERGENCY STOP push-buttons on the control panels.

CONNECTION TO POWER SUPPLIES

- b. Turn the RESET selector switch located on the main control panel
- c. Press the RESTART push-button located on the main control panel to access to the machine functions. The push-button is illuminated.

IF THE SAW BEGINS TO MOVE, PRESS THE E-STOP AND RETURN TO STEP 4 (PHASE SEQUENCE).

- d. Move the CARRIAGE BWD/FWD selector to BWD and check that the expandable hub carriage descends towards the machine base. If this is not the case, switch off the electrical power, reverse one phase (wire) in the connection and repeat the check.
5. When the connection has been correctly made press shortly the CUT push-buttons to position the blade to its rest position, away from the operator

**Important notice for users supplying machine with 60 Hz voltage.**

The machine has been factory tested and set using electrical current at the same voltage as the user, but at 50 Hz. A number of settings may have to be changed when the units are powered at 60 Hz. Please take great care when performing the first few cycles and notify the manufacturer of any machine that does not conform to the information contained in this manual.

One of the units that may be most affected by the change in the electrical frequency is the stitching unit, and in particular the rotation speed of the tyre loaded on the expandable hub and rim assembly which will increase by approximately 20%.

MACHINE USE

5. MACHINE USE

5.1. WARNINGS



The machine is built with top quality materials and with electronic, electrical, mechanical and pneumatic devices to ensure safe use.

The tyres to be processed must have been previously inspected, dried, cleaned, repaired and buffed and any objects that might have become embedded in the sidewalls or the tread during use, posing a threat to operator safety, must have been removed.

The operator must be trained to evaluate the characteristics and condition of the tyres to be processed, to carry out the adjustments and preliminary operations required by the machine and the tyre, and to perform the various process operations.

MACHINE USE**5.2. SAFETY DEVICES AND FUNCTIONS**

It is forbidden to use the emergency controls for operational reasons. Their activation is independent of the consequences they might have on the process being performed.

5.2.1. EMERGENCY STOPS PUSH-BUTTONS

Located on the machine control panel and on the front side of the stitching group there are two block – EMERGENCY STOP – push-buttons that the operator or an engineer assigned to specific operations must activate immediately should he recognise an impending risk of personal injury or damage to the machine:

When one of these push button is pressed, all the machine devices are blocked and any tyre being processed is deflated.

After an emergency block, the operator can restart the machine only when an engineer has checked that the cause of the emergency has been eliminated.

In order to restart the machine, proceed as follows.

- Release the EMERGENCY STOP push-button that has been pressed.
- Press the RESTART push-button located on the control panel to gain access to the machine functions and controls.
- The next manoeuvres depend on the operator choice.
 - a. If the cycle can be resumed from the point at which it was interrupted:
 - i. press the INFLATION push button
 - ii. press the APPLICATION – RUN push button.
 - b. If the cycle must be definitively interrupted:
 - i. set the STITCHING GROUP selector to UP to create the conditions needed to unload the tyre,
 - ii. press the RESET selector switch to set the machine in its start position.

MACHINE USE

5.3. ELECTRICAL CONTROLS

5.3.1. BUILDING ZONE CONTROL PANEL



Figure 12: building zone control panel

electrical system diagram - ref.	control label	description
70P1 indicator lamp	LINE	On when the auxiliaries circuit is powered up. If the mains switch is set to ON and this lamp is off, an authorised electrical maintenance engineer must check the lamp and/or the electrical circuit for failures.
90S2 emergency push-button yellow ringed control	EMERGENCY STOP	The operator or an engineer assigned to specific operations must activate immediately this push-button should he recognise an impending risk of personal injury or damage to the precured tread building and stitching machine.

MACHINE USE

electrical system diagram - ref.	control label	description
111S3 two-function push-button	INFLATION DEFLATION	Starts inflation or deflation of the tyre loaded on the expandable hub.
90S1 + 70P2 illuminated push-button	RESTART	Press this push-button after releasing any EMERGENCY STOP push-button. The push-button pilot lamp turns ON.
111S5 selector	RESET	Use the RESET selector to set the machine in its start position after an emergency stop.
112S5 3-position selector with return to centre	STITCHING GROUP DOWN UP	Position the selector lever to UP to move the entire stitching group away from the tyre surface. When the lever is positioned to DOWN the group descends to work position.
112S1 two-function push-button	STITCHING RUN DWELL	A single touch of the button starts the stitching operation of the twin rollers on the tread already applied and stapled. Press and hold down so that the twin stitching rollers dwell on one part of the tread. The stitching cycle is completed when the button is released.
112S3 dual-function push-button	STITCHING STOP	A single touch interrupts the stitching rollers cycle. If pressed for more than 2 seconds, the button interrupts the cycle and the stitching unit returns to the rest position.
113S2 3-position selector with return to centre	TREAD JOG FWD BWD	Precured tread application in manual mode. With the selector lever positioned to FWD tread feed is activated. When the lever is positioned to BWD the tread movement is reversed.
131P2 buzzer	-	The buzzer activates to signal the tread end.

MACHINE USE

electrical system diagram - ref.	control label	description
113S3 + 131P1 three-function luminous push-button	APPLICATION RUN STOP	<p>The first touch of the button moves the tyre to work position until when it touches the endstroke microswitch.</p> <p>The second touch of the button moves the stitching group to touch the tread strip positioned on the tyre. After a PLC controlled time the tyre starts rotating and the tread is applied. These operations are stopped automatically by the proximity switch that feels the tread edge.</p> <p>The third touch of the button stops tyre rotation if needed during the cycle.</p>
112S5 three-position selector	CARRIAGE BWD FWD	<p>With the selector lever positioned to BWD the tyre is removed away from application position and/or tread feeding bench.</p> <p>When the selector lever is positioned to FWD the tyre reaches the tread application position.</p>
131P2 (buzzer)	-	<p>This alarm sounds to warn the operator when the length of the missing tread is equal or less than 18".</p>

MACHINE USE

5.3.2. STITCHING ZONE CONTROL PANEL



Figure 13: stitching controls

electrical system diagram - ref.	control label	description
111S4 two-function push-button	INFLATION DEFLATION	Starts inflation or deflation of the tyre loaded on the expandable hub.
113S1 push-button	STITCHING CUSHION	The first touch of the button starts the stitching operation of the twin rollers on the cushion gum. The second touch of the button starts a PLC controlled automatic sequence of stitching strokes and stitching dwells of the twin rollers.
90S3 emergency push-button yellow ringed control	EMERGENCY STOP	The operator or an engineer assigned to specific operations must activate immediately this push-button should he recognise an impending risk of personal injury or damage to the precured tread building and stitching machine.
112S2 two-function push-button	STITCHING TIRE	A single touch of the button starts the stitching operation of the twin rollers on the tread already applied and stapled. Press and hold down so that the twin stitching rollers dwell on one part of the tread. The stitching cycle is completed when the button is released.
112S4 dual-function push-button	STITCHING STOP	A single touch interrupts the stitching rollers cycle. If pressed for more than 2 seconds, the button interrupts the cycle and the stitching unit returns to the rest position.

MACHINE USE

5.3.3. POLY ZONE CONTROL PANEL



Figure 14: poly zone control panel

electrical system diagram - ref.	control label	description
42R1 potentiometer	POLY SPEDD ADJ.	By turning the potentiometer, the operator can adjust the speed of the poly unwinder.
114S1 push-button	POLY ROLLER	A first touch of the button moves the poly roller to work (down) position. A second touch of the button moves the poly roller to rest (up) position.
114S2 selector	POLY UNWINDER	This selector allows to move the tread and facilitates poly removal.

MACHINE USE

5.3.4. CUTTING ZONE BI-MANUAL CONTROLS



Figure 15: cutting zone bi-manual controls

electrical system diagram - ref.	control label	description
95S1 left push-button	CUT	When pressed simultaneously (maximum delay 0.5 seconds) these push-buttons activate the cutting operation. Such operation is interrupted only when they are released; by pressing the push-buttons simultaneously, the cutter reverses its stroke to rest position.
95S2 right push-button	CUT	

5.3.5. ELECTRICAL CABINET

electrical system diagram - ref.	control label	description
10Q1 Main switch	I – ON / 0 - OFF	MAINS SWITCH. When set to 0/OFF also acts as a lockable block to cut off the power supply

5.3.6. PEDAL CONTROLS

electrical system diagram - ref.	control label	description
113S4 foot pedal	ROTATION	Press and keep depressed this pedal control to activate clockwise tyre rotation to facilitate manual operations such as the cushion gum application. Release the pedal to stop tyre rotation.

More information about the electrical system and control lay-out are contained in the *ANNEX 2* to this manual - see *ELECTRICAL SYSTEM DIAGRAM*.

MACHINE USE

5.4. PNEUMATIC CONTROLS.



Figure 16: pneumatic controls

pn. control	control label	description
three position lever with fixed central position	TREAD LIFT UP DOWN	Lowering and raising of the mobile roller bench to facilitate tread roll loading.

More information about the pneumatic system are contained in the “ANNEX 3” to this manual - see *PNEUMATIC CIRCUIT DIAGRAM*.

MACHINE USE

5.5. COMPRESSED AIR CONTROL DEVICES

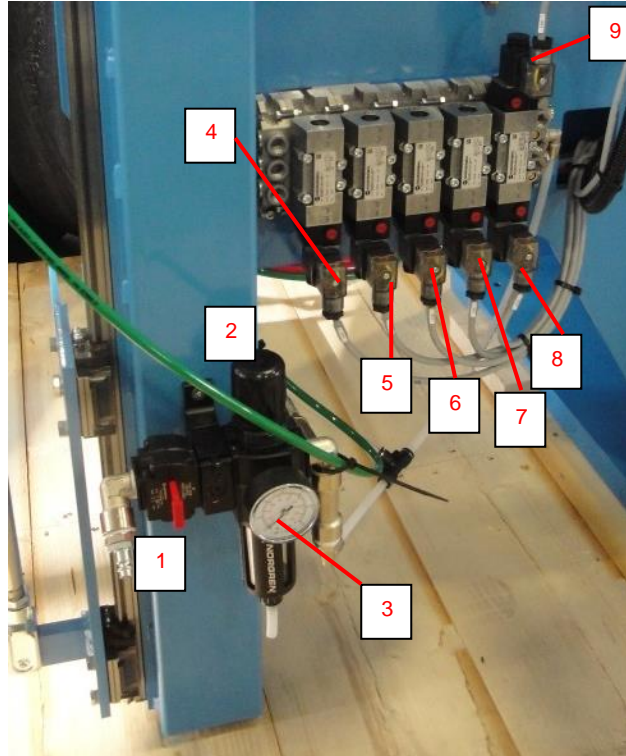

Figure 17: compressed air controls

Ref.	Pneumatic diagram-ref.	Description
1	-	Lockable inlet valve for compressed air feeding to the machine pneumatic circuit.
2	FRL1	Filter-regulator. The regulator is factory set to 8 bar (120 PSI) and this value must not be modified.
3	G6	Pressure gauge that visualizes the compressed air line value.
4	EV1	Solenoid valve controlling hub inflation.
5	EV7	Solenoid valve controlling poly pinch roller.
6	EV6	Solenoid valve controlling tread presser.
7	EV5	Solenoid valve controlling stitching twin rollers.
8	EV3/4	Solenoid valve controlling stitching group.
9		

MACHINE USE

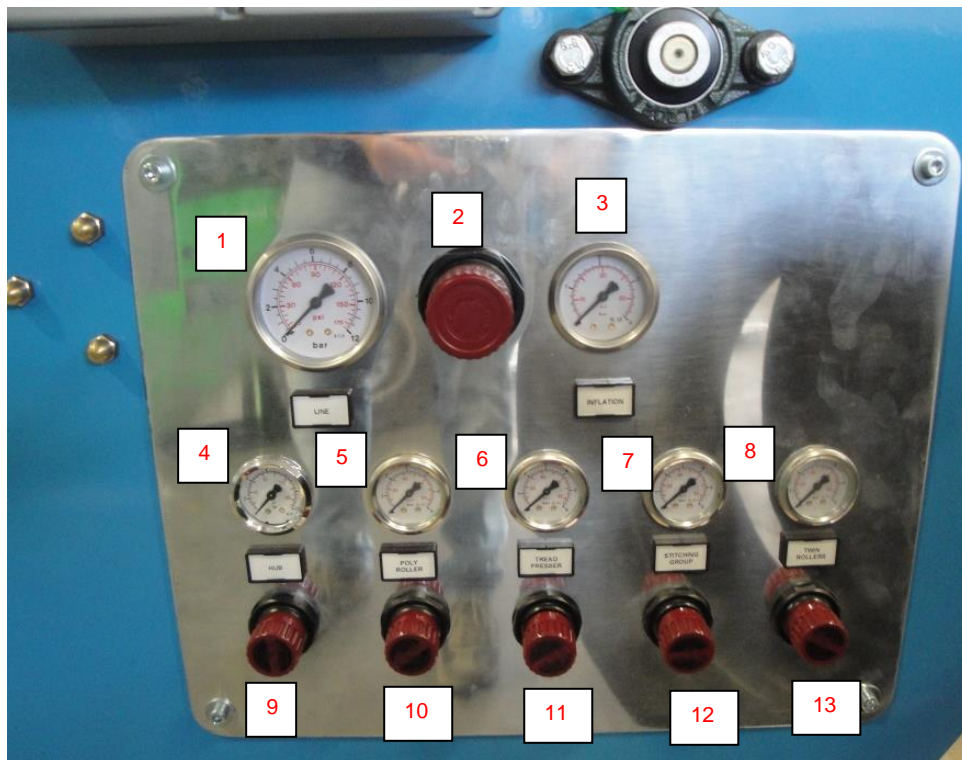

Figure 18: compressed air controls

Ref.	Pneumatic diagram-ref.	Description
1	G6A	Pressure gauge that visualizes the compressed air line value.
2	R2	Pressure regulator controlling tyre inflation pressure (factory set to 2 bar – 30 PSI).
3	G2	Pressure gauge that visualizes the tyre inflation pressure value.
4	G5	Pressure gauge that visualizes the hub inflation pressure value.
5	G7	Pressure gauge that visualizes the poly roller pressure value.
6	G3	Pressure gauge that visualizes the tread presser pressure value.
7	G1	Pressure gauge that visualizes the stitching group pressure value.
8	G4	Pressure gauge that visualizes the twin rollers pressure value.
9	R5	Pressure regulator controlling hub inflation pressure.
10	R7	Pressure regulator controlling poly pinch roller pressure (factory set to 5 bar – 70 PSI).
11	R3	Pressure regulator controlling tread presser pressure (factory set to 2 bar – 30 PSI).
12	R1	Pressure regulator controlling stitching group pressure (factory set to 1,8 bar – 25 PSI).
13	R4	Pressure regulator controlling twin rollers pressure (factory set to 2 bar – 30 PSI).

MACHINE USE

THE CONTROL DEVICES LISTED ABOVE ARE CONNECTED IN SEQUENCE AND SET SO AS TO GUARANTEE THE INFLATION REQUIRED BY THE MACHINE OPERATION AND TO KEEP THE PRESSURE WITHIN THE SAFETY LIMITS.

THESE SETTINGS MUST NOT BE CHANGED AND THE DEVICES MUST BE MAINTAINED IN PERFECT WORKING ORDER.

DO NOT PUSH THE INFLATION push button to turn on inflation if the tyre is not loaded on the expandable hub.

If the rubber rim on the hub is worn, it may not support inflation. As a result, it may tear and harm the operator or other persons in the vicinity.

More information about the pneumatic system are contained in the “ANNEX 3” to this manual - see *PNEUMATIC CIRCUIT DIAGRAM*.

MACHINE USE**5.6. MECHANICAL ADJUSTMENTS****5.6.1. CHANGING THE RIM OF THE EXPANDING HUB**

Before starting a stitching cycle, the operator has to check that the size of the expandable rubber rim on the hub is suitable for the size of the tyre to be processed.



Qualified personnel may work on the machine only after the electrical and pneumatic feeds have been disconnected.

How to fit the rubber rim on the expandable hub

1. Fit the rim by sliding the seats of its sections on the hub wings. The rapid air coupling on the rim must be correctly positioned with respect to the length of the two compressed air feed tubes coming from the expandable hub. Push the rim carefully.
2. Turn the four rim fastening pins counter clockwise.
3. Connect the fittings of the two compressed air feed tubes coming from the expandable hub to the rim.



The frequency of expandable rim changing can be reduced by working in series.



DO NOT press the INFLATION push-button to turn on inflation if there is no tyre on the hub. If the rubber rim on the hub is worn, it may not support inflation. As a result, it may tear and harm the operator or other people in the vicinity.

MACHINE USE**5.7. OPERATOR WORK STATION**

When tyre loading has been carried out, the operator must stand close to the control panel and perform the manual adjustments and operations required by the cycle.



The area surrounding the work stations must be kept clean and, in particular, it must be kept free of slippery substances, tools or objects that might impede safe operator movement.

MACHINE USE**5.8. OPERATION**

Before beginning a production cycle the operator must check that the size of the rim mounted on the expandable hub and the tread width/pattern are correct for the size of tyre to be machined.

5.8.1. MACHINE EMPTY RESTART

At the start of every day or workshift, or when the electrical power supply is cut off for maintenance work, it is recommended to perform a MACHINE EMPTY RESTART to set up the machine control devices to operate correctly. In order to do so, proceed as follows.

1. Position the mains switch of the electrical cabinet to I/ON.
2. Activate the machine pneumatic circuit.
3. The rotary cutter is to its rest position.
4. The LINE lamp on the stitching unit control panel is switched ON.
5. Release the EMERGENCY STOP push-button on the control.
6. Turn the RESET selector switch located on the control panel.
7. Press the RESTART push-button located on the control panel to gain access to the machine functions.

When these operations have been completed the machine is ready for a cycle

5.8.2. INFLATING AND DEFLATING THE TYRE

Load the tyre on the expandable hub rim and press the INFLATION / DEFLATION push-button.

When the INFLATION / DEFLATION push button is pressed, tyre casing inflation is activated and performed in **two successive stages**:

- During the first stage the solenoid valve YV1 activates the expansion of the rim for the short period of time controlled by the PLC.
- Next, the solenoid valve YV2 comes into operation, starts the tyre casing inflation up to 2 bar (30 PSI) and maintains this pressure during the process. The pressure regulator that controls the inflation is factory set to 2 bar (30 PSI) during machine testing and inspection.

Two spring-operated safety valves, installed on the joint of the expandable hub, release the compressed air if the pressure to which they have been set is exceeded during the above mentioned inflation stages.

Press again the INFLATION / DEFLATION push button to deflate the tyre casing.



Do not press the INFLATION push button to start inflation when the tyre is not loaded on the expandable hub. A rubber rim in poor condition might not withstand the inflation and may cause injury to the operator or other persons in the vicinity.

MACHINE USE**5.8.3. APPLYING THE CUSHION GUM ON THE BUFFED TYRE**

To facilitate this operation the machine provides:

- the foot pedal that rotates the tyre,
- the CUSHION GUM STITCHING push-button:

The first touch of the push button starts the stitching operation of the twin rollers on the cushion gum.

The second touch of the push button starts a PLC controlled automatic sequence of stitching strokes and stitching dwells of the twin rollers.

5.8.4. PRECURED TREAD ROLL LOADING AND FEEDING

1. Set the lever of the TREAD LIFT pneumatic control to DOWN to set the movable roller bench in the loading position.
2. Place the precured tread roll on the bench with the tread pattern uppermost and with the edge in the direction of the machine stitching group.



Remove any dangling piece of protective poly and/or precured tread that might threaten operator safety and the mechanical components during loading.

3. Set the TREAD LIFT pneumatic control to UP. The movable roller bench rises and stops automatically at the height of the machine fixed roller bench.
4. Use the handwheels provided to adjust the distance between the guiding pins that hold the tread in the centre.
5. Set the lever of the POLY PINCH ROLLER pneumatic control to UP to separate the two rollers. Separate the poly from the tread and fix the poly end on the lower roller.
6. Set the lever of the POLY PINCH ROLLER pneumatic control to DOWN to bring together the two rollers
7. Press the POLY UNWINDER push-button and keep it depressed to detach the poly from the tread and to make the tread advance until when its leading edge reaches the cutter lower guide which indicates where the cut will be made.
8. Press the two CUT push-buttons together so that the operator's hands are well away from the pinch and cut points. The blade moves to cut the tread transversely. Hold down the two CUT push-buttons until the cut has been completed. By releasing the two CUT push-buttons the blade stops. By pressing once more the two CUT push-buttons the blade reverses its stroke.

MACHINE USE

5.8.5. TREAD APPLICATION AND STITCHING CYCLE

1. Press the INFLATION/DEFLATION push-button so that the tyre loaded on the expandable hub is inflated to 2 bar.
2. Press the APPLICATION push-button that starts flashing.
3. Press for the second time the APPLICATION push-button. The buffed and cemented tyre loaded on the expandable hub moves towards the roller bench which carries the tread ready for application start. The tyre stroke is stopped by a microswitch.
4. Feed the tread until its leading edge is 13-25 mm. (1/2" – 1") beyond the stitching group central roller.
5. Press for the third time the APPLICATION push-button to lower the stitching group on the tread edge applied to the tyre. After a few seconds, a PLC controlled delay, the tyre rotation starts and stops when the tread leading edge is detected by a proximity switch.
6. Press the two CUT push-buttons together so that the operator's hands are well away from the pinch and cut points. The blade moves to cut the tread transversely. Hold down the two CUT push-buttons until the cut has been completed. By releasing the two CUT push-buttons the blade returns to rest position. When the rotating blade reaches its rest position the tyre moves away from the roller bench.
7. Position the STITCHING GROUP selector to UP and rotate the tyre manually to bring the tread joint to a convenient position for the operator when he is standing in front of the stitching unit.
8. Position the STITCHING GROUP selector to DOWN to lower the stitching group on the tread.
9. Arrange the joint (splice) between the two ends of the tread and staple them together.
10. Control the stitching operation by STITCHING - RUN/DWELL push-button.

A **single touch of the button** starts the tyre rotation and operates the twin stitching rollers: they start pressing on the tread and move from the centre towards the tyre shoulders where they stop due to the intervention of a proximity switch.

Press and hold down the button so that the twin stitching rollers insist on a certain area of the tread. Release the button to allow the twin rollers to complete their stroke towards the tyre shoulders.

11. The stitching cycle can be interrupted moving the selector STITCHING GROUP to UP: the tyre stops rotating and the twin rollers return to their rest central position ready to start a new cycle.
12. Stitching operation can also be interrupted by the STITCHING STOP push-button that pressed one time interrupts the cycle and kept depressed for more than 2 seconds ends the cycle.

5.8.6. HOW TO LEAVE THE MACHINE AT THE END OF THE WORKSHIFT

1. Unload the tyre from the expandable hub and rim assembly.
2. Move the *tread lift* selector to "down".
3. Set the main electrical cabinet mains switch to "off".

MAINTENANCE

6. MAINTENANCE

6.1. SAFETY RULES FOR MAINTENANCE AND REPAIRS

- Maintenance denotes all servicing, inspection and repair work.
- Mechanical and electrical repairs and adjustments may only be performed by qualified personnel. It is forbidden for unauthorized persons to perform any work on the machine.
- The required adjustments, maintenance work and inspections must be performed at the specified intervals and in compliance with the instructions regarding the replacement of components/subassemblies.
- You must not carry out any maintenance operations, apart from visual checks, until you have first cut off the electrical current and the compressed air supplies and discharged any residual air in the machine by operating the pneumatic controls under load less conditions.
- You must comply with environmental protection regulations with regard to the disposal of waste and parts replaced.
- To prevent personal injury during maintenance, adjustments or repairs, you must only use appropriate and correctly calibrated tools and instruments.

6.2. RULES REGARDING WORK ON ELECTRICAL COMPONENTS

- Work on the electronics and the electrical components may only be carried out by qualified electricians.
- Mark off the work area with a chain or red/white tape and appropriate danger signs.
- Use only original fuses with the required amperage. Defective fuses must not be repaired but replaced with fuses of the same kind.
- The electrical equipment and electrical system on board the machine must be inspected and checked at regular intervals. Defects, such as loose connections, damaged power cables and worn protection device contacts, must be eliminated immediately.
- Use only insulated tools.
- Should it be necessary to work on live parts, the electrician must be accompanied by a second person who, in the event of an emergency, should press the BLOCK/EMERGENCY STOP button.
- Cut off the power supply before disconnecting or connecting up plug/socket electrical connectors.

IT IS STRICTLY FORBIDDEN TO CARRY OUT ELECTRODE OR WIRE WELDING ON ANY PART OF THE MACHINE, ON OTHER MACHINES IN THE VICINITY OR ON MACHINES CONNECTED TO THE SAME MAINS POWER SUPPLY. If necessary, contact Matteuzzi srl to establish the required precautions. Permanent damage may be done to the computer and equipment connected to it and your warranty voided.



Any work required on the machine must be performed by qualified personnel and only after the electrical and pneumatic power supplies have been cut off.

MAINTENANCE

6.3. MAINTENANCE OPERATIONS

6.3.1. DAILY MAINTENANCE

description	personnel
<p>At the start of every day or work shift check that the block - emergency stop buttons are in perfect working order.</p>	operator
<p>Keep the operator floor area clean, removing rubber dust and any objects that might make it slippery.</p> <p>Do not use an air hose to blow off dust. Instead, please use a vacuum system. Permanent damage may be done to different parts and your warranty voided.</p>	
<p>Remove the polyethylene film detached from the tread from the poly pinch roller and dispose of it in accordance with prevailing regulations.</p>	
<p>Clean thoroughly the parts exposed to process dust.</p> <p>Do not use an air hose to blow off dust. Instead, please use a vacuum system. Permanent damage may be done to different parts and your warranty voided.</p>	
<p>Visually check the wear of the rubber rim of the expandable hub and ask for its replacement, if necessary.</p>	
<p>Visually check the wear of the circular blade of the rotary cutter and ask the mechanical maintenance engineer to replace it if it is worn out.</p> <p>See instructions provided in the Retooling chapter.</p>	

MAINTENANCE

6.3.2. MONTHLY MAINTENANCE

description	personnel
Check the efficiency of the silencers installed on the compressed air outlets. Keep them clean and ask for them to be replaced when necessary.	operator
Cut off compressed air supply to discharge the condensate from the compressed air filter bowl.	mechanical maintenance engineer
The electrical equipment and electrical system on board the machine must be inspected and checked at regular intervals. Defects, such as loose connections, damaged power cables and worn protection device contacts, must be eliminated immediately.	electrical maintenance engineer

6.3.3. QUARTERLY MAINTENANCE

description	personnel
Clean thoroughly and grease the screws on which the twin rollers move horizontally. Use a commercially available product specifically designed for mechanical lubrication.	mechanical maintenance engineer
Perform lubrication of critical machine parts, as described at par. 6.3.3.1.	

6.3.3.1. Lubrication

	<p>The following operations must be performed by a qualified mechanical maintenance engineer and only after the electrical and pneumatic power supplies have been cut off.</p> <p>Use a grease gun filled with a commercially available product that is made specifically for mechanical lubrication.</p>
---	---

MAINTENANCE

ASSEMBLY: CENTRAL ROLLER

Feed with grease the pillow block nipples for central roller rotation.

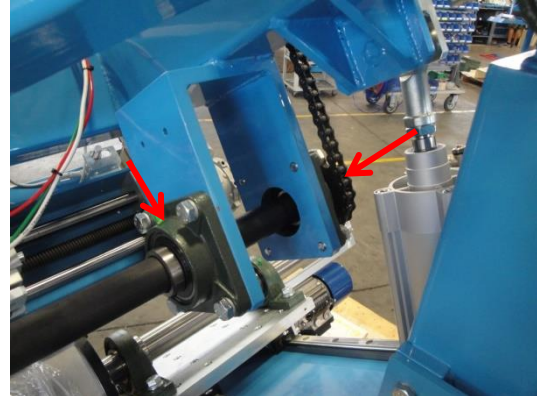

Feed with grease the pillow block nipples for central roller tilting.

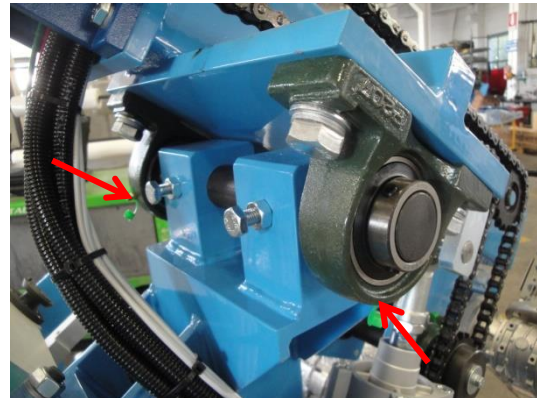

ASSEMBLY: HUB

Feed with grease the pillow block nipples of the hub rotation shaft.

Feed the greasers the linear guides for up/down movement of the expanding hub and rim assembly.

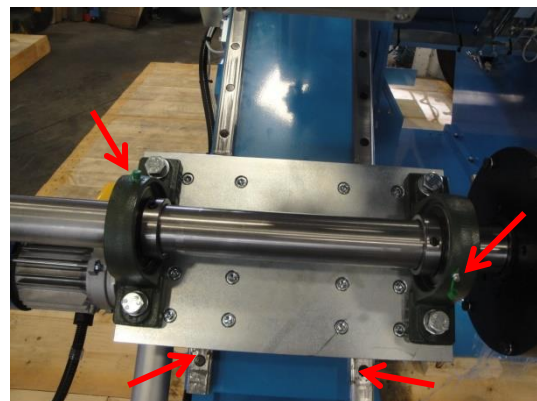

MAINTENANCE

ASSEMBLY: TREAD CUTTER

Clean and grease the chains and the guides on which the tread cutter moves.

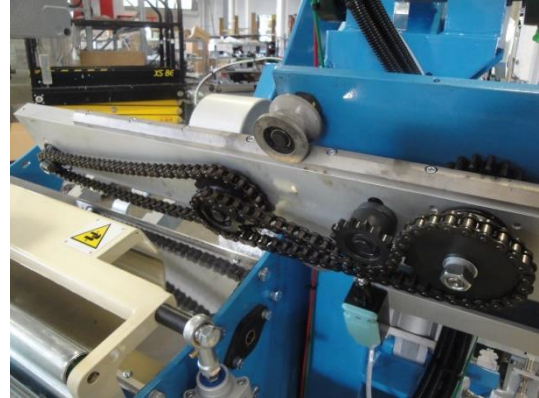

ASSEMBLY: TREAD LIFT

Feed the greasers of the tyre lift linear guide.

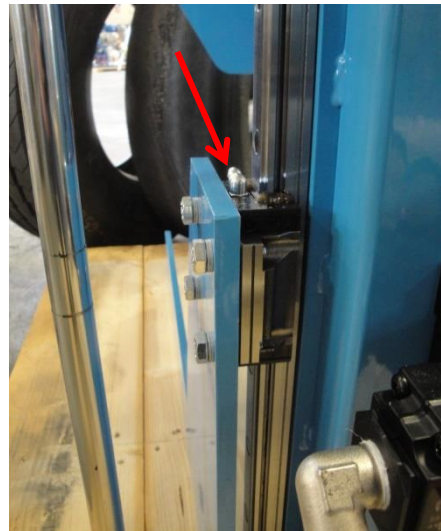

MAINTENANCE

ASSEMBLY: ROLLERS

Feed with grease the various pillow block nipples for roller rotation.

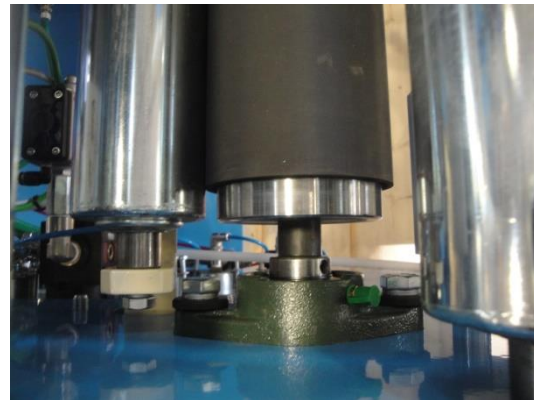
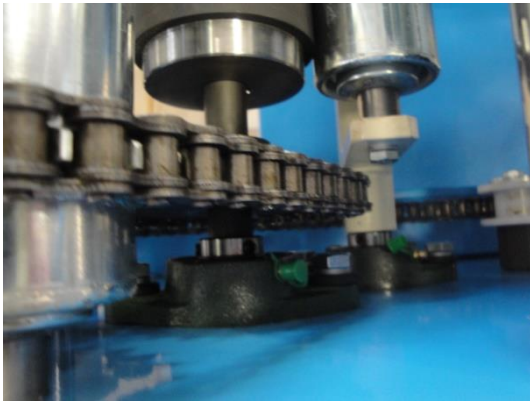

6.3.3.2. Gearboxes

The gearboxes fitted on the machine are life-lubricated.

6.3.4. SEMIANNUAL MAINTENANCE



description	personnel
Check the state of the air operated machine components and equipment.	mechanical maintenance engineer
Check and; if necessary; tighten the bolts and nuts of the operating parts.	

MAINTENANCE

6.4. RETOOLING

6.4.1. CHANGING THE BLADE IN THE TREAD CUTTER

Worn blades diminish the quality of the cut. The operator must visually check the condition of the cutter blade and, if necessary, request replacement.

	<ul style="list-style-type: none"> • This operation may only be performed by a mechanical maintenance engineer or trained personnel. • To prevent damaging the fastening screw, use only the spanner provided with the machine and no others. • Proceed with the blade replacement only after cutting off the electrical and pneumatic power supplies, as described below
	<p>During blade replacement the mechanical maintenance technician or trained personnel must wear protective gloves.</p>

How to change the blade in the cutter:

- Press CUTTER UP push-button to return the cutter to its raised position.
- Cut off the electrical and pneumatic power supplies.
- Using the 90° spanner 13 mm, loosen the screw locking the cutter blade and replace the blade.
- Replace every component, exactly reproducing the original configuration.
- Carry out a machine empty restart procedure - see par. 5.8.1.

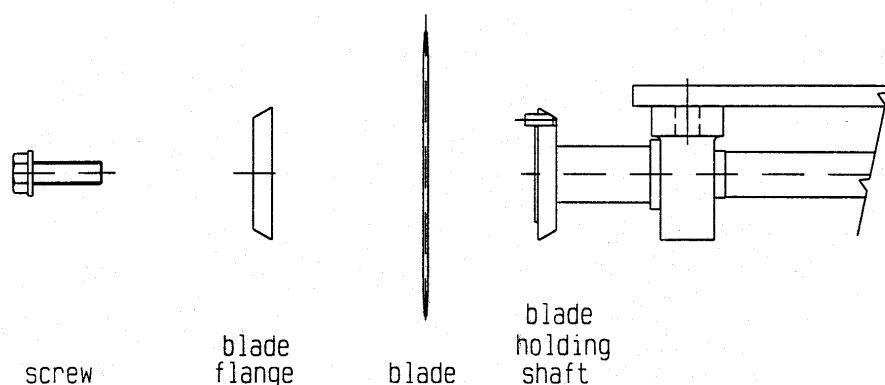

Figure 19: blade retooling

MAINTENANCE

6.5. ACCESSORIES PROVIDED

Qtys	description	use
1	spanner - 10 mm./13 mm.	Various maintenance operations
1	Allen wrench - 4 mm.	
	Allen wrench - 5 mm Allen wrench - 6 mm	

6.6. ORDERING SPARE PARTS

When ordering spare parts, please specify the following:

- the serial number and year of manufacture of your machine, as indicated on the plate fitted to the machine,
- the reference number of the part as indicated on the drawings illustrating the machine assemblies - see annex 1,
- the part description as given on the parts lists - see annex 1,
- any other details you think may be useful to identify exactly the replacement part you require.

DECOMMISSIONING

7. DECOMMISSIONING

7.1. STOPPING THE MACHINE

When stopping the machine definitively, before disassembling, proceed with the following:

- Disconnect the machine from the electrical power supplies;
- Disconnect the machine from the compressed air supplies (if present);
- Disconnect the machine from the hydraulic power supplies (if present).

7.2. DISASSEMBLY AND DISPOSING

Once the operations have been carried out, all machine parts can be removed for scrapping.

When disassembling the machine comply meticulously with the handling indications set out in this manual.

In particular:

- Do not use non-compliant or worn ropes or cables with a lifting capacity lower than the machine weight;
- Move the machine carefully and make sure that people are not standing in the operating area of the lifting equipment;
- Do not stand under suspended loads;
- Pay particular attention to suspended parts and relative risks.

7.3. DISPOSING AND SCRAPPING

There are no hazardous components or materials in the machine that could cause problems during decommissioning.

Once the single components have been disassembled, start dividing them by material as follows.

- Ferrous material: frame, guard, fittings, etc.
- Aluminium: flanges, etc.
- Plastic material: gaskets, cables, etc.
- Electric material: motors, panel, equipment.

During scrapping, retrieve any components that can be retrieved and reused.

ALL THE MACHINE COMPONENTS, AFTER HAVING BEEN SEPARATED BY MATERIAL, MUST BE SCRAPPED BY SPECIALISED COMPANIES THAT OPERATE IN COMPLIANCE WITH THE LEGAL REQUIREMENTS IN FORCE IN THE USER'S COUNTRY.

LIST OF ANNEXES

8. LIST OF ANNEXES

Annex No.	Description of the folder contents
1	DRAWINGS ILLUSTRATING THE COMPONENT PARTS OF THE MACHINE TOGETHER WITH PART LISTS
2	ELECTRICAL SYSTEM DIAGRAM
3	PNEUMATIC CIRCUIT DIAGRAM

RAS 405 BUILDER

OPERATION AND MAINTENANCE MANUAL



MACCHINE PER PNEUMATICI E PER I PROCESSI DI RICOSTRUZIONE
EQUIPMENT FOR THE TYRE AND RETREADING INDUSTRIES

matteuzzi srl
Via Serra 1/E - 3
40012 Calderara di Reno - Bologna - ITALY
Tel. +39 - 051726351
Fax +39 - 051726283
matteuzzi@matteuzzi-srl.com

www.matteuzzi-srl.com



MACCHINE PER PNEUMATICI E PER I PROCESSI DI RICOSTRUZIONE
EQUIPMENT FOR THE TYRE AND RETREADING INDUSTRIES

matteuzzi srl
Via Serra 1/E - 3
40012 Calderara di Reno - Bologna - ITALY
Tel. +39 - 051726351
Fax +39 - 051726283
matteuzzi@matteuzzi-srl.com

www.matteuzzi-srl.com

ANNEXES 1, 2, 3

to OPERATION AND MAINTENANCE MANUAL

RAS 405

Year of manufacture 2021

Serial no. MAT-21117

Manufacturer MATTEUZZI SRL
Via Serra, 1/E - 3
40012 CALDERARA DI RENO
BOLOGNA - Italy

Importer

- 1 DRAWINGS ILLUSTRATING THE COMPONENT PARTS OF THE MACHINE TOGETHER WITH PART LISTS
- 2 ELECTRICAL SYSTEM DIAGRAM
- 3 PNEUMATIC CIRCUIT DIAGRAM

This manual is an integral part of the machine. It must be kept close to hand when using the machine and must be available for transfer to other users if necessary

*disegni e lista dei
componenti meccanici*

*mechanical part list
and drawings*

*description et plans
des composants mécaniques*

*Zeichnungen und
Mechanikteile-Liste*

*dibujos y lista de los
componentes mecánicos*

contents

Assembly description	drawing ref.
STAND FOR ROLLS	M40277.00
TWIN ROLLERS	M40419.04
CENTRAL ROLLER	M40420.04
EXPANDABLE HUB	M40423.03
TREAD POSITIONER	M40863.08
TREAD POLY UNWINDER	M40864.02
TREAD LIFT	M40865.03
TREAD CENTERER	M40868.03
PRECURED TREAD CUTTER	M41940.07
MACHINE FRAME	M42220.01

DISEGNO – DRAWING – PLAN – ZEICHNUNG – DIBUJO **M40277.00**

rif. ref. rep.	Descrizione – Description – Beschreibung – Descripción		Q.tà Q.ty Q.tè Menge Cant.
1	11321.0	STAND FOR POLY – FIXED FRAME	1
2	11322.0	STAND FOR POLY – MOBILE COLUMN	1
3	11323.0	SPACER RING	1
4	11324.0	COVER	2
5	10106.0	TAPERED ROLLER	4
6	20180.0	RAPID CLAMP, M63P-M6X20	4
7	11327.0	STOPPER	1
8	23836.0	WASHER, I.D. 6 UNI6592	2
9	23898.0	SCREW, HEXAGONAL HEAD DIA.6 L=45 MM.	2
10	11328.0	SHAFT	1
11	23899.0	WASHER, D.12X45X4 ZINC-PLATED	1
12	23843.0	WASHER, D.10 UNI6592 ZINC-PLATED	1
13	23690.0	SCREW, HEXAGONAL HEAD M10X35 ZINC-PLATED	1

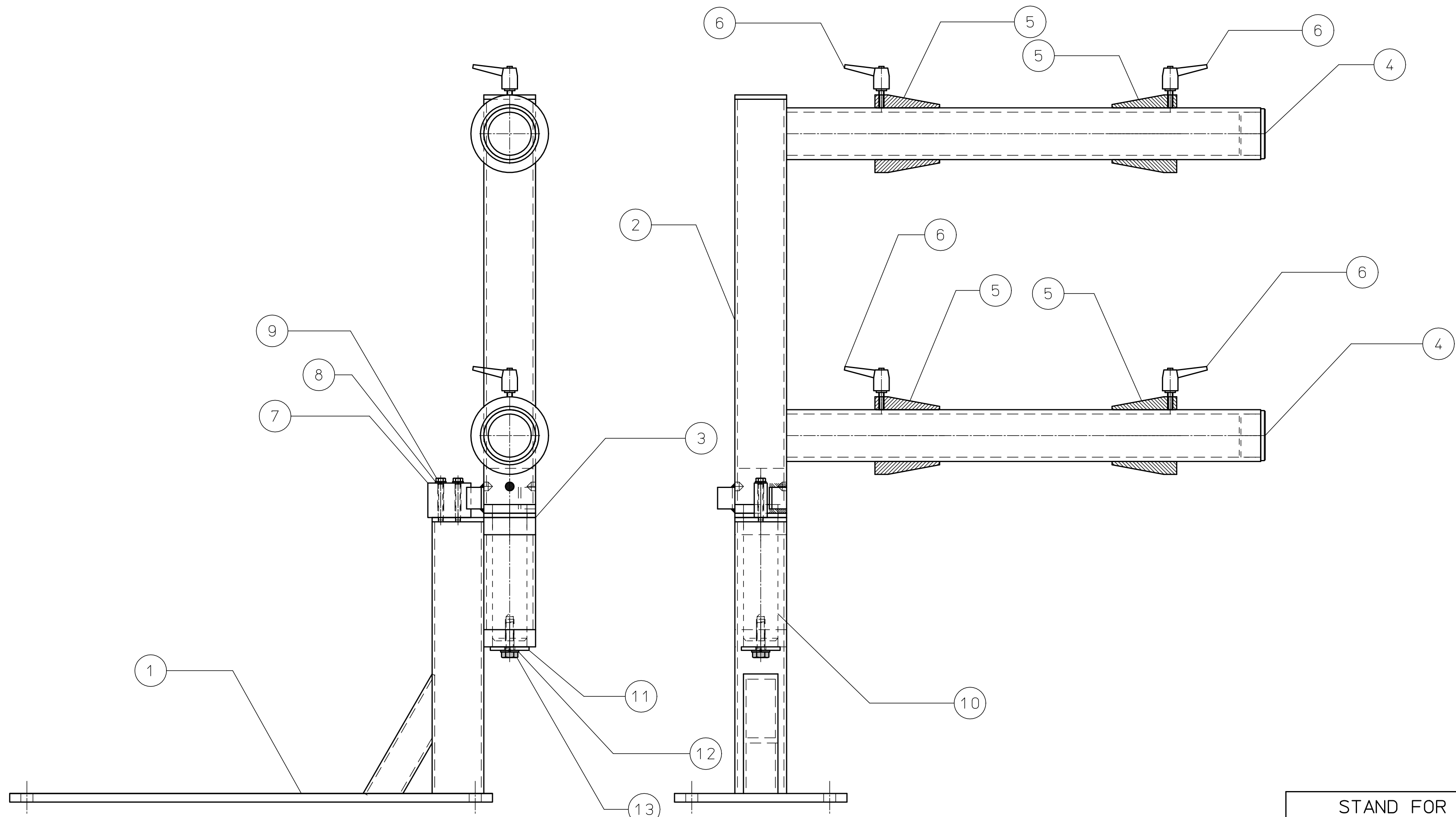

DISEGNO – DRAWING – PLAN – ZEICHNUNG – DIBUJO **M40419.04**

rif. ref. rep.	Descrizione – Description – Beschreibung – Descripción		Q.tà Q.ty Q.tè Menge Cant.
1	11223.2	FRAME	1
2	11216.0	SUPPORT	1
3	11217.0	SUPPORT	1
4	11218.0	SUPPORT	1
5	11219.0	FLANGE FOR GEARBOX	1
6	11220.0	SLEDGE	2
7	11214.0	BUSHING, L.H. FITMENT	1
8	11215.0	BUSHING, R.H. FITMENT	1
9	11213.0	SCREW	1
10	11212.0	SHAFT	2
11	11221.0	SPACER	3
12	14524.00	SPACER	1
13	12276.0	FEELER	1
14	11222.0	PROTECTION	1
15	14525.00	PROTECTION	1
16	14530.00	SUPPORT	2
17	14528.01	PLATE	2
18	29051.0	CYLINDER, COMPACT FESTO D.40X80 ADN-40-80-IPA	2
19	14529.2	SUPPORT	2
20	14523.1	SUPPORT	2
21	14513.0	SHAFT	4
22	11224.0	ROLLER	2
23	11225.0	PIN	2
24	11226.0	SPACER	2
25	20705.0	MOTOR, M63 4 POLES 0,25HP B5	1
26	20476.4	GEARBOX, RMI40FL 1/20 PAM63 B5	1
27	23060.0	BALL BUSHING, KH 2030 PP	8
28	10611.0	WASHER	2
29	22708.0	PROXIMITY SWITCH, AM1/AP-2H D=12N.0	2
30	22711.0	CONNECTOR, C/WITH 10 M. CABLE	2

DISEGNO – DRAWING – PLAN – ZEICHNUNG – DIBUJO **M40419.04**

rif. ref. rep.	Descrizione – Description – Beschreibung – Descripción		Q.tà Q.ty Q.tè Menge Cant.
31	21934.0	SNAP RING, I.D.32	1
32	20069.0	BALL BEARING, SKF 6002-2RS1	1
33	20012.0	SNAP RING, I.D. 20	1
34	20067.0	BALL BEARING, 6004 2RS	4
35	22517.0	SNAP RING, I.D. 42	2
36	24691.0	SCREW, HEXAGONAL HEAD - DIA.12 - L=60 MM.	2
37	21193.0	KEY, 6X6X40	1
38	20441.0	ELBOW, "L" 1/4"-T4	4
39	14536.0	SPACER FOR PROXIMITY SWITCH SUPPORT	2
40	14429.0	FRONT PANEL	1
41	78416.0	SUPPORT FOR PROXIMITY SWITCH, R.H. FITMENT	1
42	78417.0	SUPPORT FOR PROXIMITY SWITCH, L.H. FITMENT	1
43	31087.00	PROXIMITY SWITCH, IS-12-C2-S2 M12	2
44	31088.00	CONNECTOR, TEM 1204 100 FRD-6 10 MT.	2

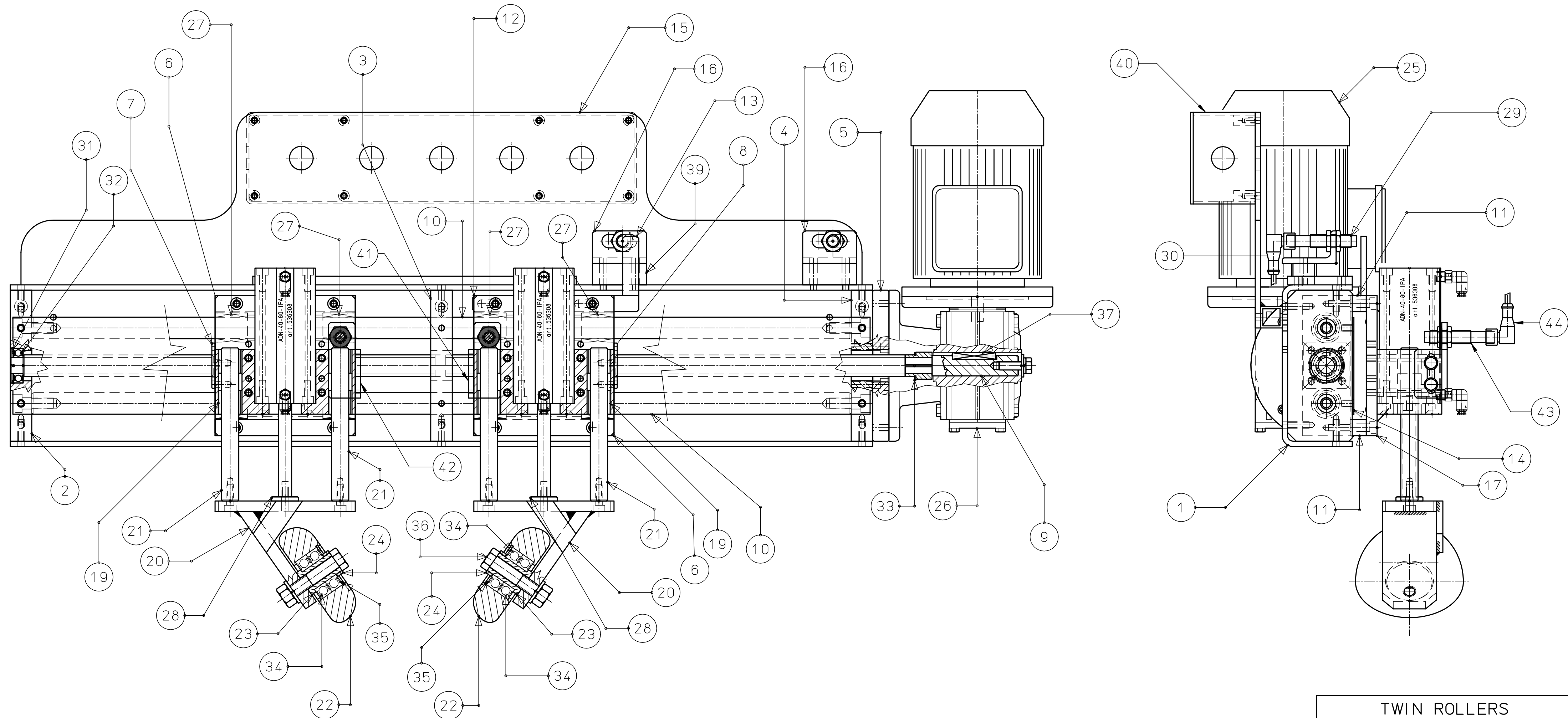

DISEGNO – DRAWING – PLAN – ZEICHNUNG – DIBUJO **M40420.04**

rif. ref. rep.	Descrizione – Description – Beschreibung – Descripción		Q.tà Q.ty Q.tè Menge Cant.
1	23565.0	PILLOW BLOCK, UCF207	2
2	14484.1	MOVABLE ARM	1
3	21108.0	PILLOW BLOCK, UCP 207	2
5	14521.0	CENTRAL ROLLER	1
6	27741.0	GEARBOX, RMI70 S r.1/49 PAM 80 B14	1
7	20759.0	MOTOR, R80 2/6P 0,75/0,14HP B14 WITH BRAKE	1
9	14461.0	PINION	2
10	14454.0	SHAFT	1
11	14556.0	CHAIN TENSIONING PINION	1
12	14462.0	CHAIN TENSIONING PINION	1
13	14476.0	SUPPORT	1
14	14445.0	PIN	1
15	22516.0	KEY, 8X7X100	1
16	14557.0	CHAIN, 5/8 L=1968.5	1
17	14500.0	PROTECTION	1
18	14532.1	CHANNEL FOR CABLES	1
19	21012.0	WASHER, I.D.8.5X35X4	3
20	22318.0	CONNECTING LINK, 5/8"S	1
21	20067.0	BALL BEARING, 6004 2RS	4
22	22517.0	SNAP RING, I.D.42	2
23	20012.0	SNAP RING, I.D.20	2
24	21049.0	KEY, 8X7X20	2
25	72093.1	SHAFT FOR ROLLER	1
26	72092.0	SHAFT FOR ARM	1
27	84570.00	SUPPORT	2
	24454-0	HEXAGONAL HEAD SCREW M8x70	4

DISEGNO – DRAWING – PLAN – ZEICHNUNG – DIBUJO **M40423.03**

rif. ref. rep.	Descrizione – Description – Beschreibung – Descripción		Q.tà Q.ty Q.tè Menge Cant.
1	23803.0	PILLOW BLOCK, UCP 211	2
2	14487.0	SUPPORT	1
3	14488.0	PLATE	1
4	14496.1	PLATE	1
5	14498.0	REAR CONNECTION FOR LINEAR ACTUATOR	1
6	14499.0	FRONT CONNECTION FOR LINEAR ACTUATOR	1
7	14530.0	SUPPORT FOR PROXIMITY SWITCH	1
8	20711.0	MOTOR, GR.63 2P 0,35HP B14	1
9	14471.0	PLATE	1
10	14472.0	PLATE	1
11	14535.0	LINEAR GUIDE, LH30 L=640	2
12	14505.0	TRAY	1
13	13100.01	EXPANDABLE HUB	1
14	30376.0	STOP RING ABU 55 DIN 705	2
15	72091.0	SUPPORT	1
16	14536.0	SPACER	1
17	14537.0	SUPPORT	1
18	22708.0	PROXIMITY SWITCH, AM1/AP-2H-3W D.12	2
19	22711.0	CONNECTOR C/WITH 10 M. CABLE	2
20	21812.0	FITTING, ELBOW CONNECTOR ¼"GS	1
22	20646.2	SAFETY VALVE, ¼" 2,5 BAR	1
23	22255.0	QUICK EXHAUSTER, VSR ½"	1
25	20580.0	FITTING, 3/8" MALE TO ¼" MALE ADAPTER	1
26	20510.0	NIPPLE, M1/2"-F3/8"	1
29	14534.0	LINEAR ACTUATOR,ECV1 VRS C=400 R1/10	1
30	20426.0	FITTING, STRAIGHT CONNECTOR ¼"T8	1
31	21931.0	FITTING, STRAIGHT CONNECTOR M 3/8"	1

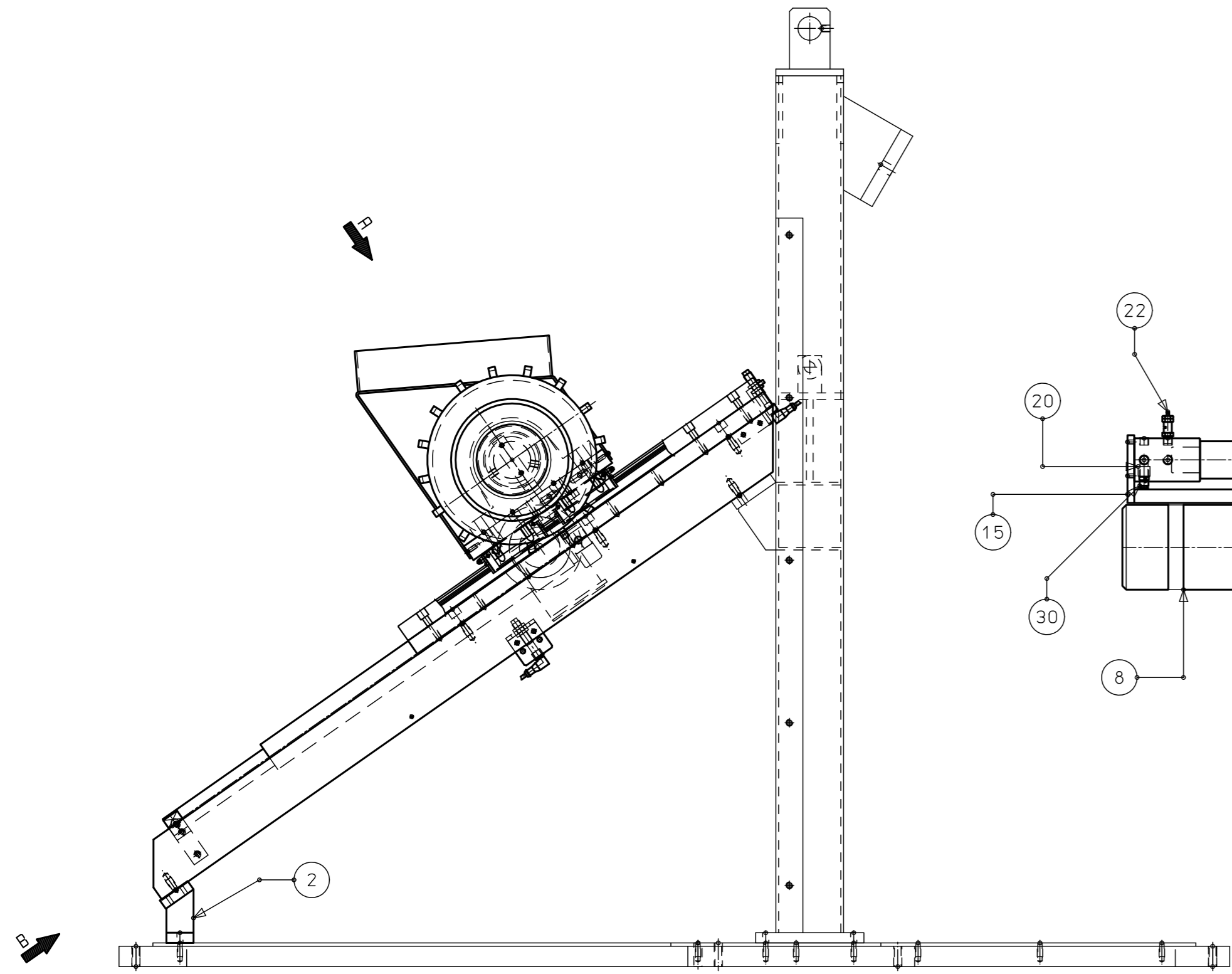

VIEW FROM "B"

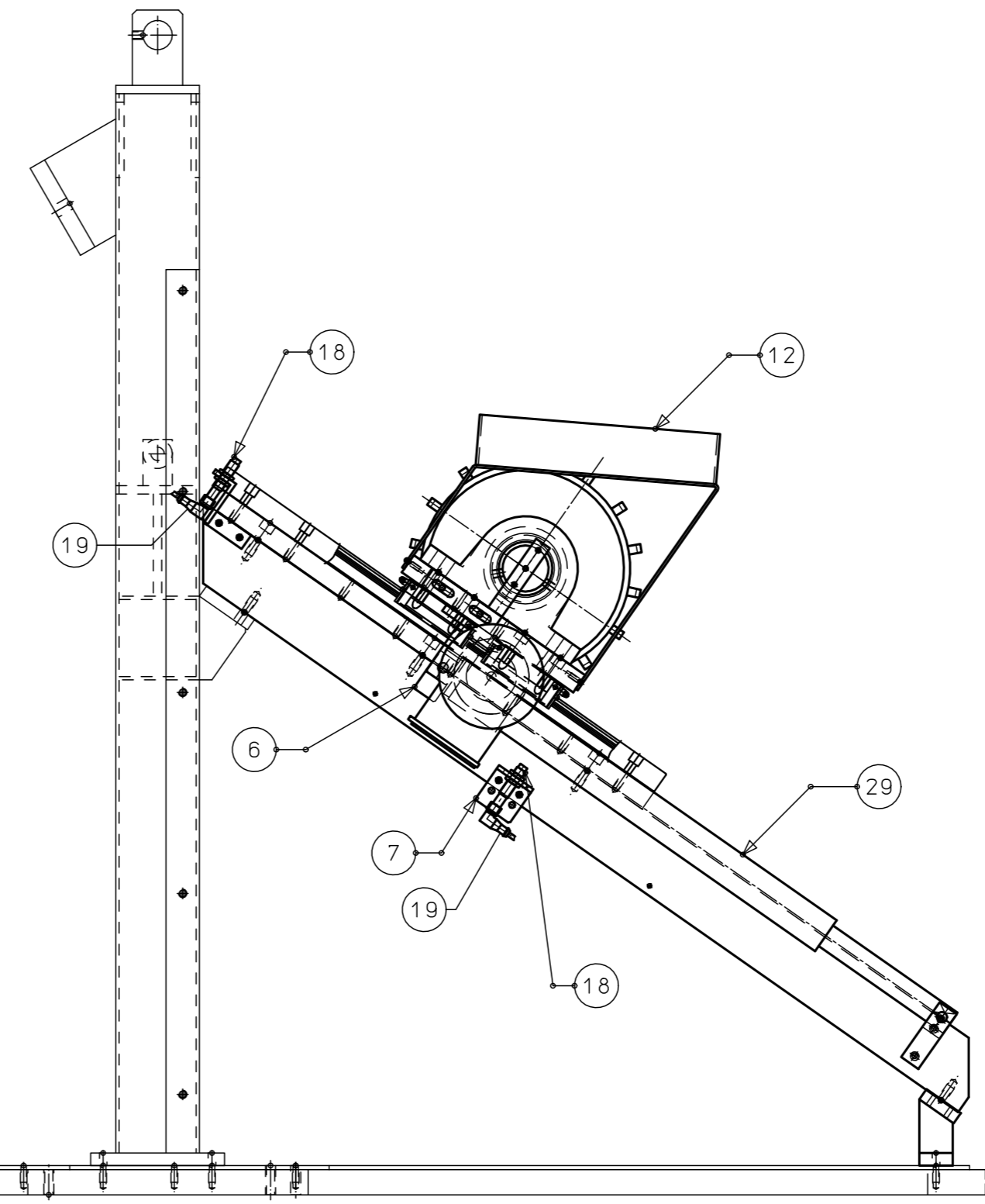
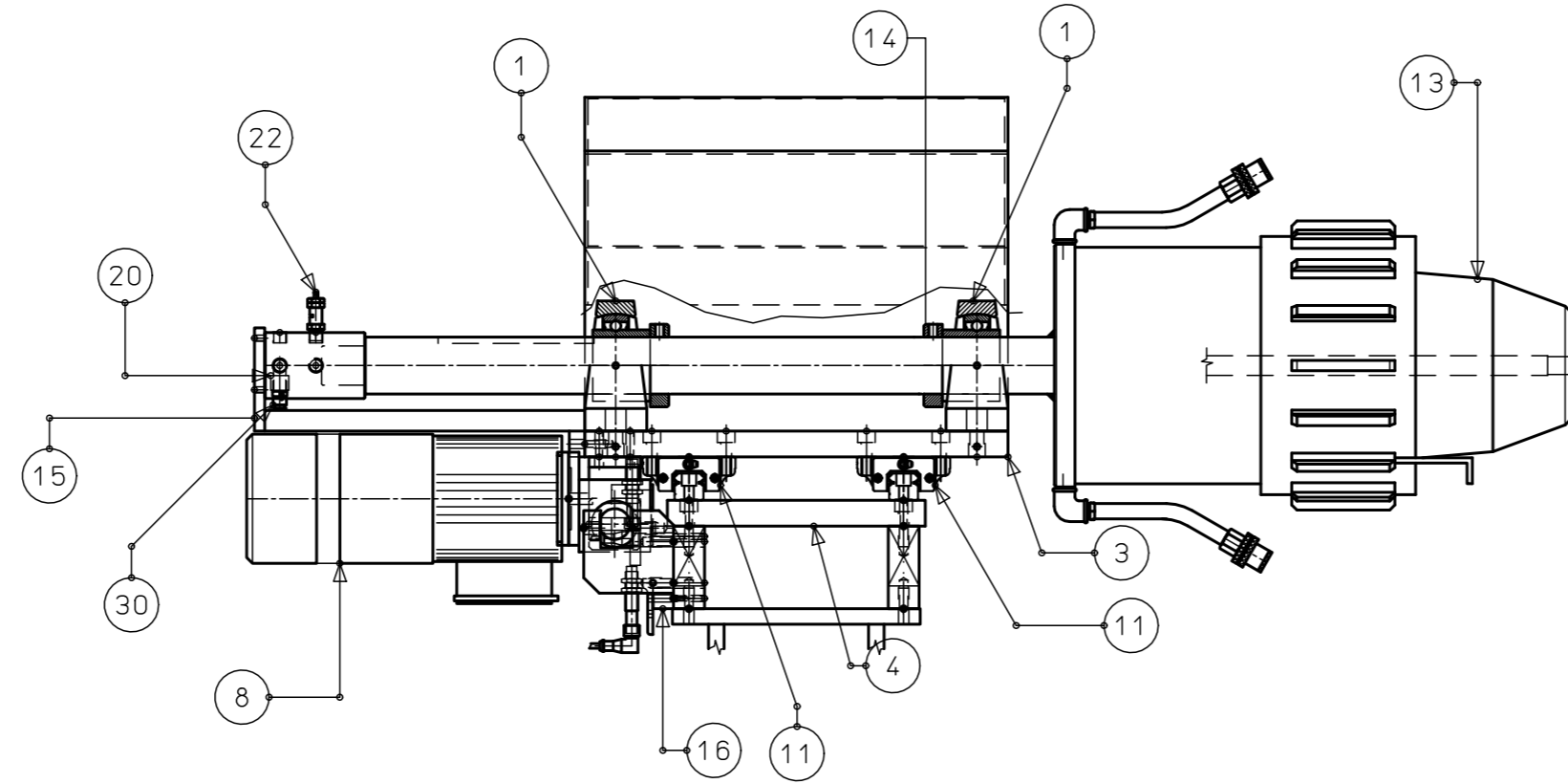

VIEW FROM "A"

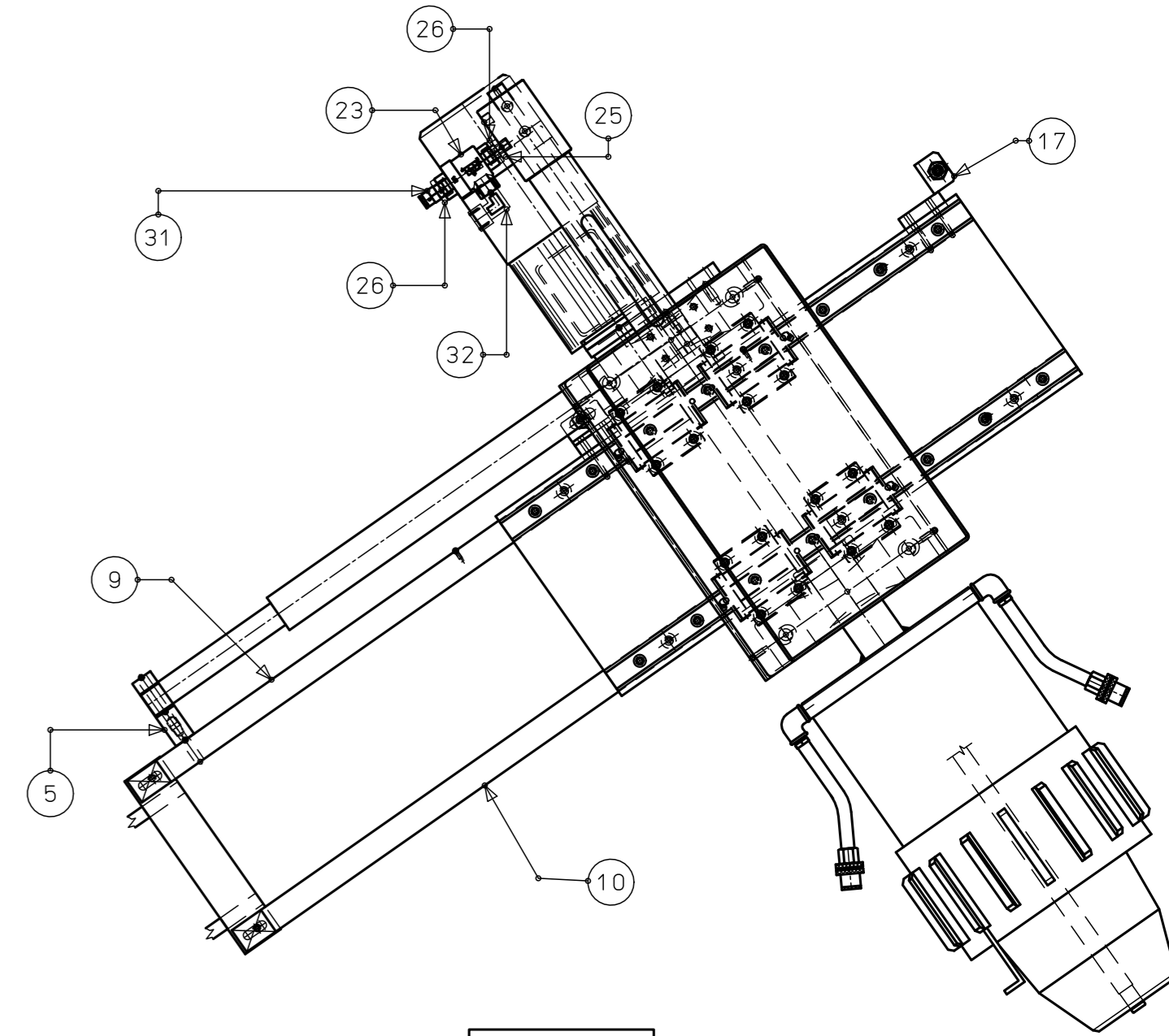

DISEGNO – DRAWING – PLAN – ZEICHNUNG – DIBUJO **M40863.08**

rif. ref. rep.	Descrizione – Description – Beschreibung – Descripción		Q.tà Q.ty Q.tè Menge Cant.
1	14436.0	PLATE	1
2	14435.1	PLATE	1
3	14432.0	ROLLER FOR TOOTH	1
4	14434.1	PLATE	1
5	14439.0	PIN	1
6	14438.0	BRACKET	1
7	14433.0	SHAFT	2
8	76537.0	BUSH, 12-15-12 bronze	4
9	28956.0	BUSH, 20-28-35-20 bronze	4
10	14431.1	TOOTH	1
11	14437.0	SUPPORT FOR LIMIT SWITCH	1
12	20274.0	COLLAR, ABU 20 DIN 705	2
13	14481.0	BAR	3
14	25370.0	LIMIT SWITCH, SIEMENS 3SE5-112-0CD02	1
15	22711.0	CONNECTOR, c/with 10 m. cable	1
16	22708.0	PROXIMITY SWITCH, PM1 AP 2H D=12	1
17	14553.0	PIN	1
18	23852.0	SCREW, HEXAGONAL HEAD M6X30 UNI5739	1
19	23861.0	SCREW, HEXAGONAL HEAD M6X25 UNI5739	1
20	25071.0	SPRING, CO 22x300 L=115	1
21	25072.0	SPRING, TR 151 POS. 34	1
22	30558.0	CYLINDER, ISO FESTO D.40X25 DNCB-40-2 5-PPV-A	1
23	27376.0	HINGE, MALE NORGREN D.40 QA/8040/27	1
24	23554.0	ROD EYE, M12X1.25 R.H.FEMALE	1
25	25365.0	SNAP RING, I.D 6	2
26	72071.0	SPACER FOR CYLINDER	1

DISEGNO – DRAWING – PLAN – ZEICHNUNG – DIBUJO **M40863.08**

rif. ref. rep.	Descrizione – Description – Beschreibung – Descripción		Q.tà Q.ty Q.tè Menge Cant.
27	21135.0	SEEGER RING, O.D.12	1
28	72072.0	PIN FOR CYLINDER	1
29	72070.1	PLATE	1
30	72067.0	FRAME	1
31	72074.0	BUSHING, TPN 20	1
32	70695.0	KNOB D.80	1
33	84539.0	KNOB	1
34	14510.0	THREADED BUSHING, TPN20 R.H.	1
35	14514.0	MOBILE SIDE PLATE	1
36	14561.0	MOBILE SIDE PLATE	1
37	14560.0	THREADED BUSHING, TPN20 L.H.	1
39	21995.0	SEEGER RING E 25	2
40	72068.0	SCREW, TPN 20 L.H. fitment	1
41	72069.0	SCREW, TPN 20 R.H. fitment	1
42	72075.0	PLATE	1
43	82373.1	JOINT	1
44	20066.0	BALL BEARING, 6005 2RS	2
45	72073.0	SCREW	1
46	72076.0	FLANGE	1
47	20069.0	BALL BEARING, SKF 6002-2RS1	2
48	72077.0	FLANGE	2
49	20437.0	FLOW REGULATOR, 1/4" T.8 MV380814	2
50	27492.1	ROLLER, ALFA 32/10 B3 X606 Y612 Z632 W/SPRING STAINLESS STEEL 304	1
53	23890.0	NUT, HEXAGONAL M6 UNI5588	2
54	71887.01	SHIM	2

DISEGNO – DRAWING – PLAN – ZEICHNUNG – DIBUJO **M40863.08**

rif. ref. rep.	Descrizione – Description – Beschreibung – Descripción		Q.tà Q.ty Q.tè Menge Cant.
55	71889.01	PIN	4
56	20686-0	SNAP RING E 17	4
57	21816-0	SNAP RING I 35	4
58	21276-0	BALL BEARING 6003 2RS	4
59	23912-0	HEXAGONAL NUT M10 UNI5589 ZINC.	4
60	71888.00	ROLLER D.80	4
61	23869-0	HEXAGONAL SOCKET HEAD CAP SCREW M10X25 UNI5931 ZINC.	4

OPTIONAL ITEMS

rif. ref. rep.	Descrizione – Description – Beschreibung – Descripción		Q.tà Q.ty Q.tè Menge Cant.
38	14520.00	CENTRING ROLLER	4
52	28993-0	SCREW UNBRAKO M10 12X30	4

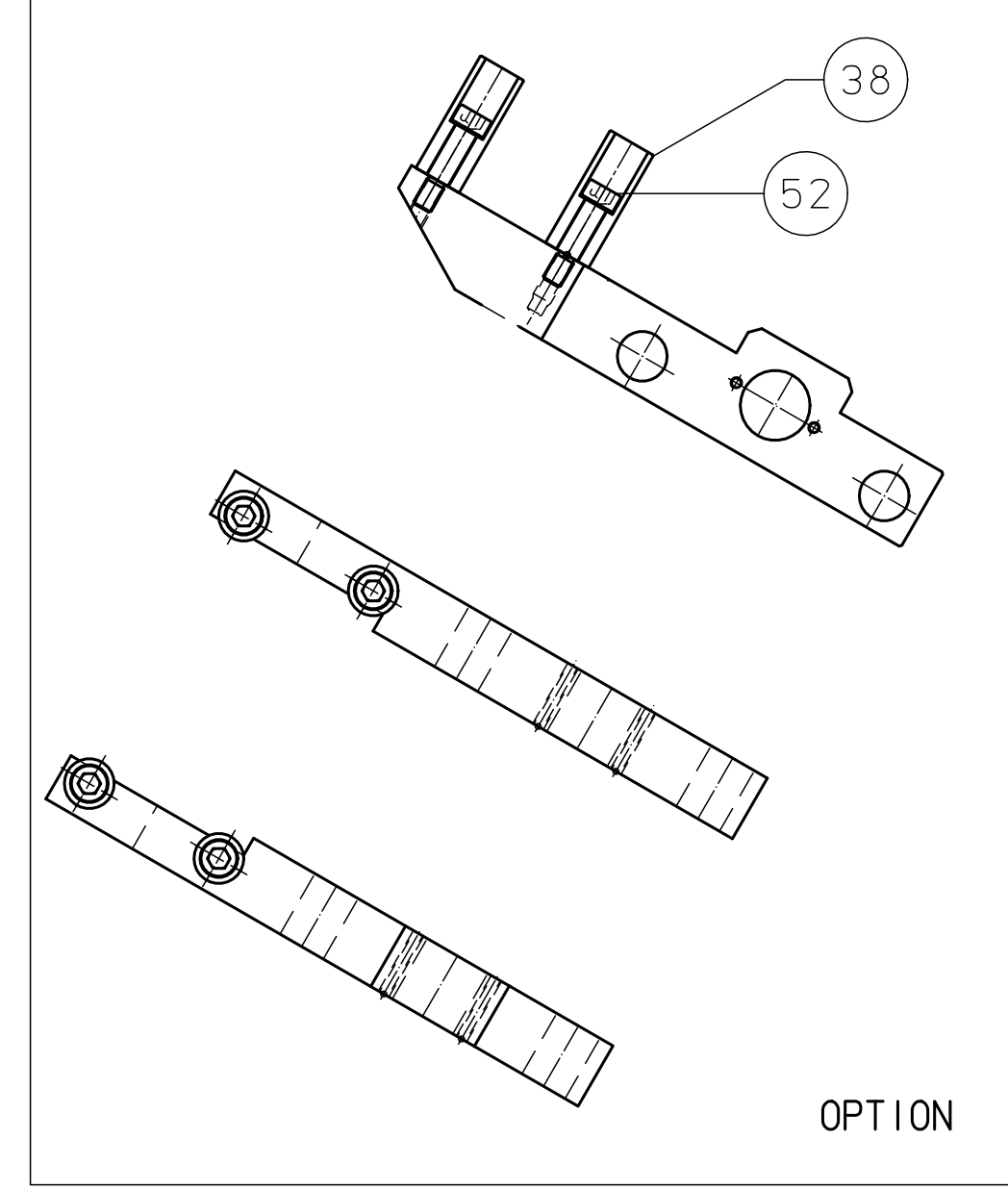
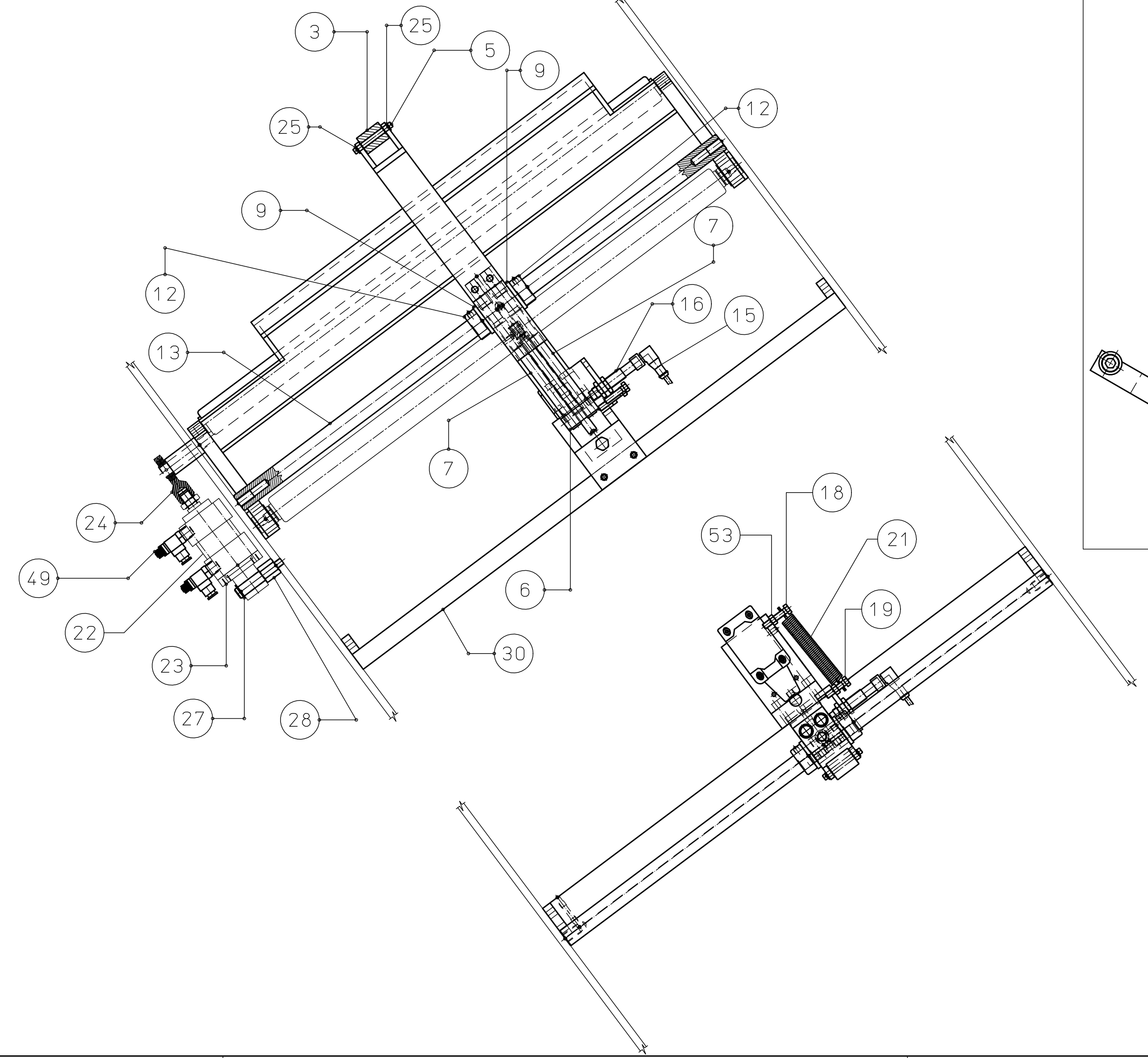
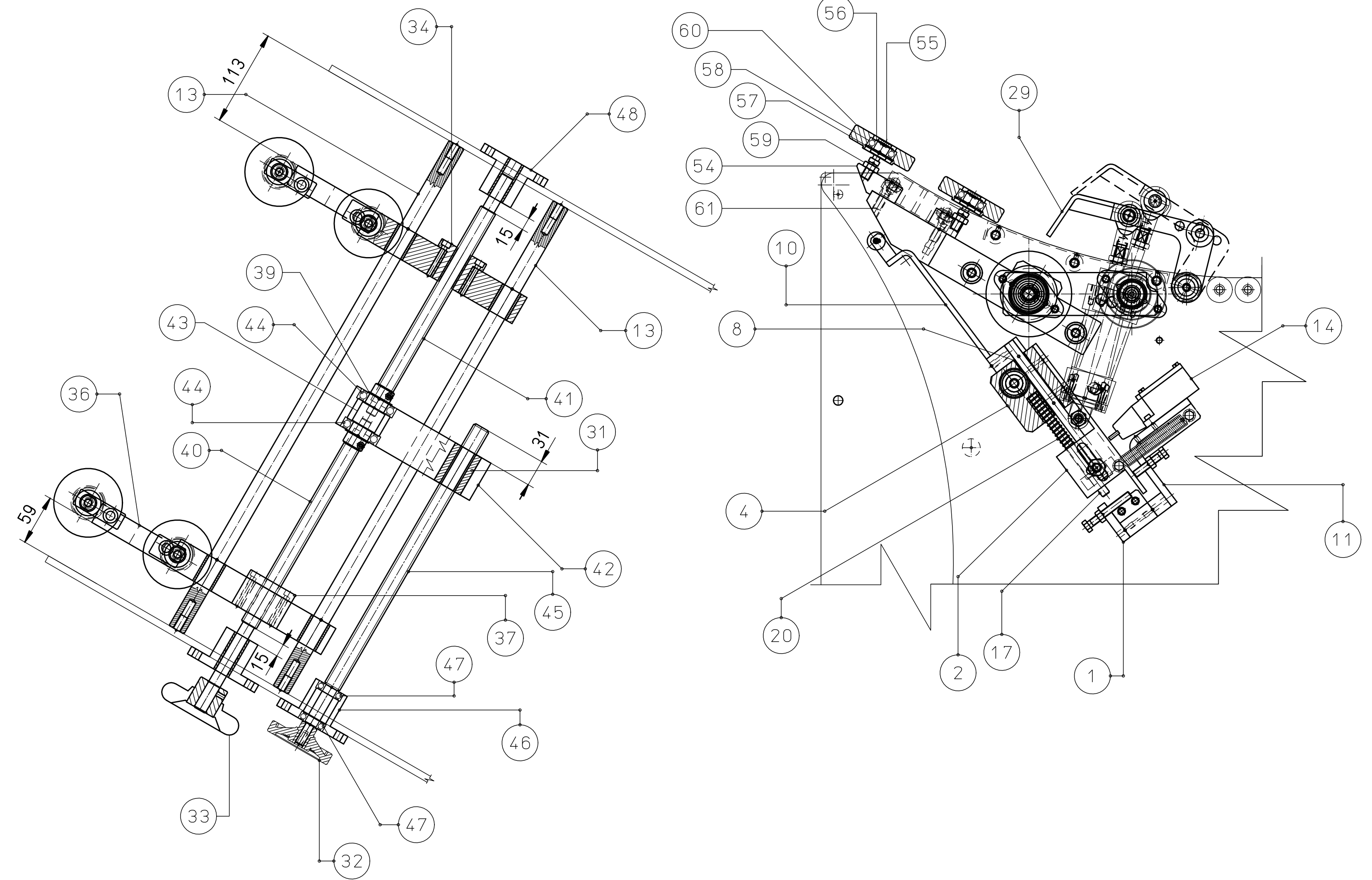
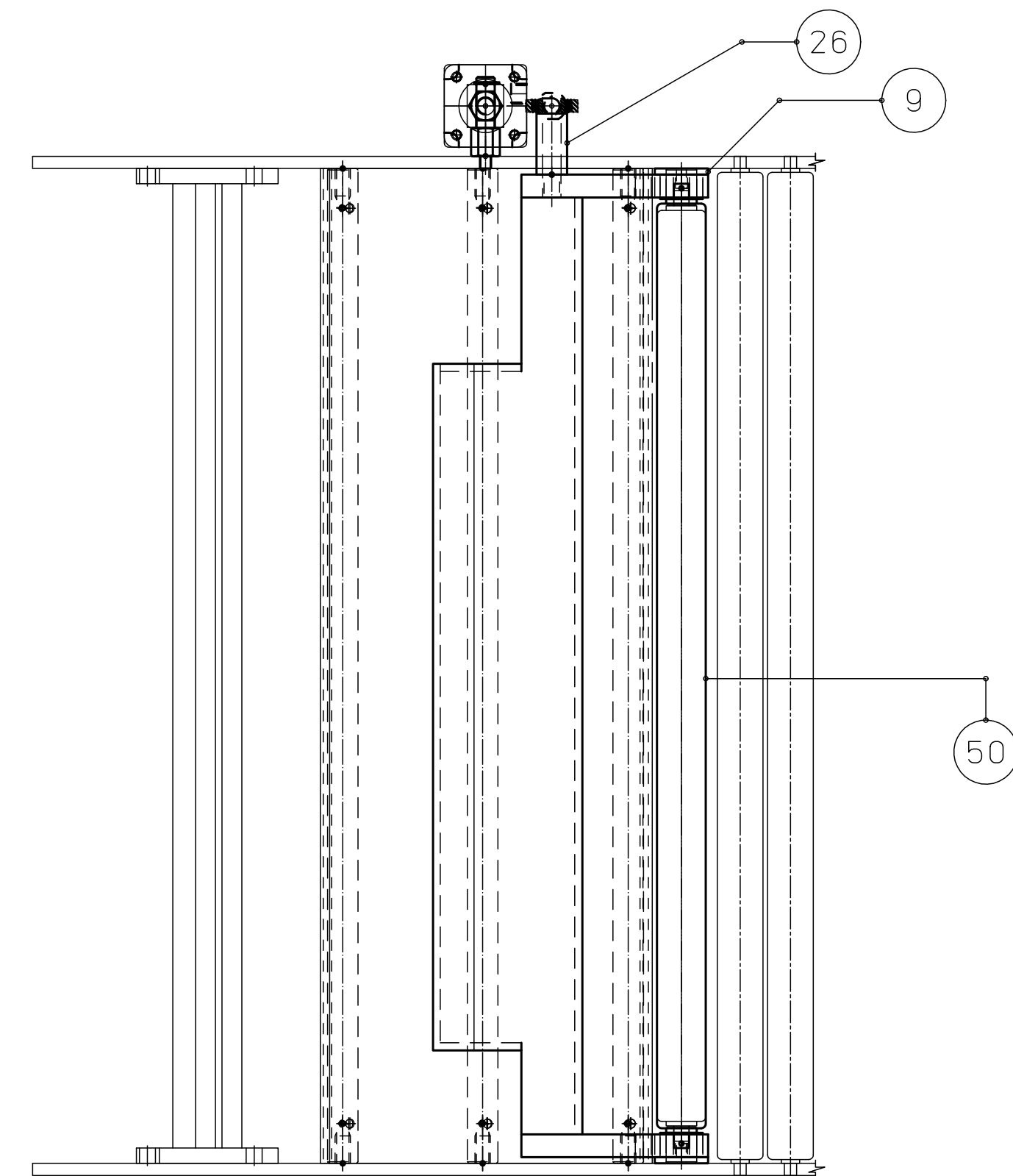

DISEGNO – DRAWING – PLAN – ZEICHNUNG – DIBUJO **M40864.02**

rif. ref. rep.	Descrizione – Description – Beschreibung – Descripción		Q.tà Q.ty Q.té Menge Cant.
1	21012.0	WASHER, D.8.5x35x4 UNI 6602	5
2	72088.1	DRIVEN ROLLER	1
	72087.1	ROLLER	1
	15009.0	CROWN GEAR	1
3	72084.0	LEVER FOR CONTRAST ROLLER	1
4	21400.0	PILLOW BLOCK, UCFL202	3
5	10191.0	PROTECTIVE BRUSH	1
6	12142.1	CONTRAST ROLLER	1
7	12148.1	ROLLER	1
8	72085.0	SHAFT	1
9	72086.0	PLATE	1
10	72090.0	SPACER FOR GEARBOX	1
11	23449.2	GEARBOX, RMI28FL 1/28 PAM63 B14	1
12	12298.0	JOINT PIN	4
13	27377.0	HINGE, FEMALE D.32 NORGREN QA/8032/23	1
14	29050.0	CYLINDER, ISO FESTO D. 32X50 DNCB-32-50 PPV-A	1
15	23184.0	CLEVIS, ISO M10X1,25	1
16	20252.0	KEY, 6x6x20	1
17	23913.0	HEXAGONAL SOCKET SET SCREW,UNI 5923 M5x16	2
18	20107.0	KEY, 5x5x20 UNI 6604	1
19	15011.1	PINION	1
20	15012.0	TENSIONER	4
21	14701.0	CHAIN	1
22	24657.0	MOTOR, GR63 4P 0,25HP B14	1
23	21193.0	KEY, 6x6x40	1
24	15296.0	PROTECTION	1

DISEGNO – DRAWING – PLAN – ZEICHNUNG – DIBUJO **M40864.02**

rif. ref. rep.	Descrizione – Description – Beschreibung – Descripción		Q.tà Q.ty Q.té Menge Cant.
25	72089.0	PIN	5
26	72096.0	PLATE	1
27	20128.0	PILLOW BLOCK, UCFL204	1
28	20446.0	FLOW REGULATOR, 1/8" DIA. 8 HOSE (458080)	2
29	72107.0	TENSIONER	1

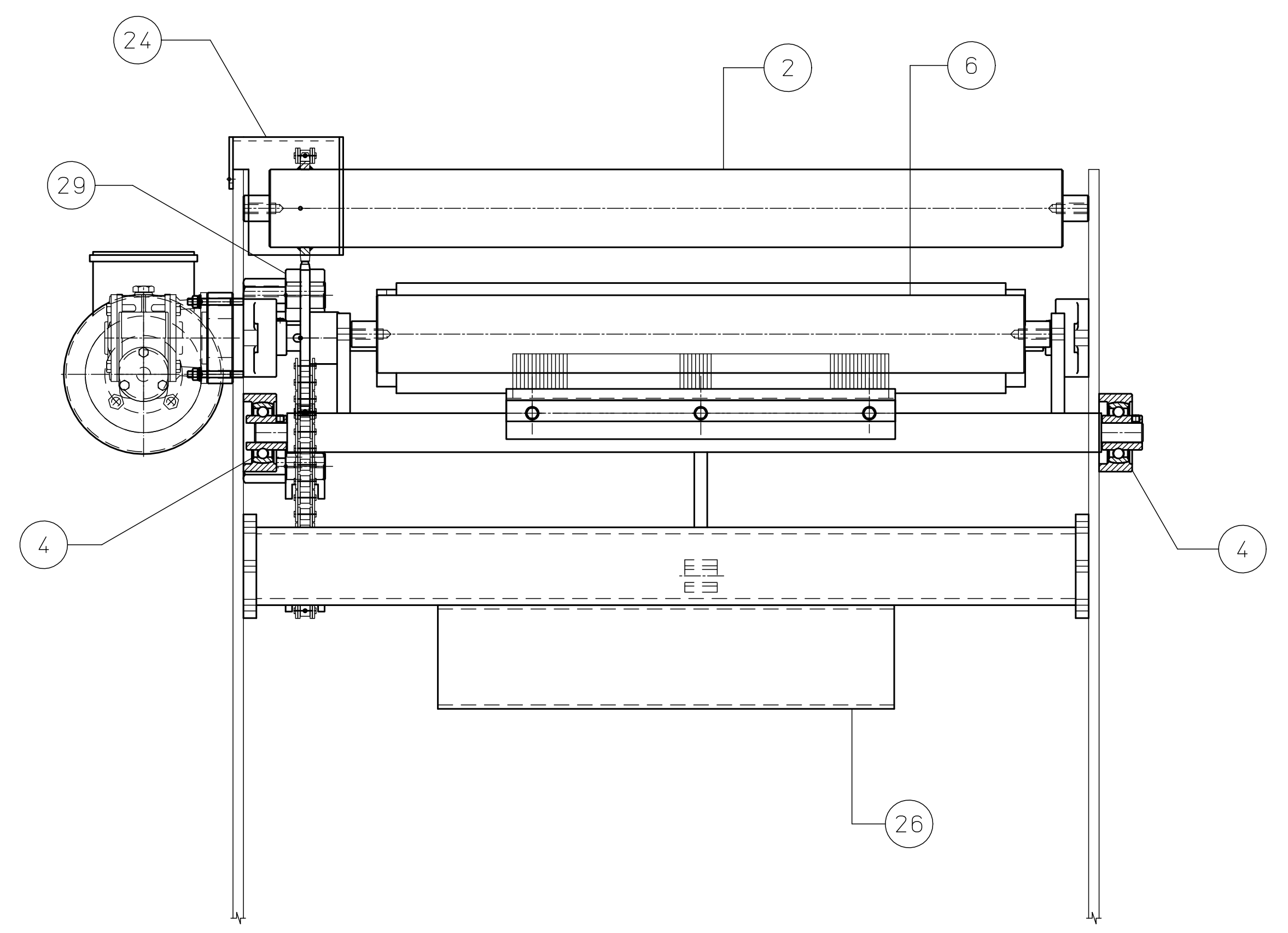
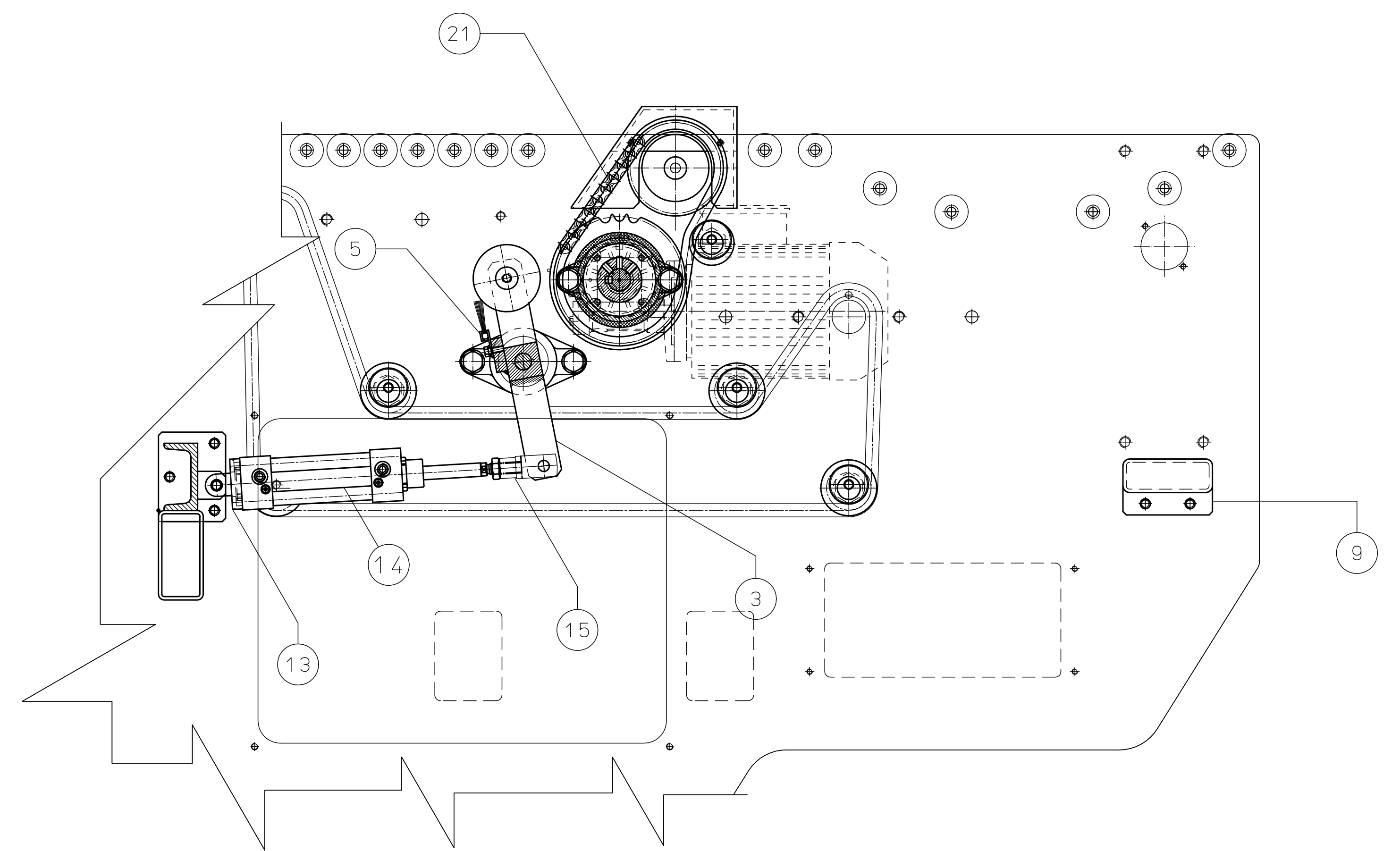
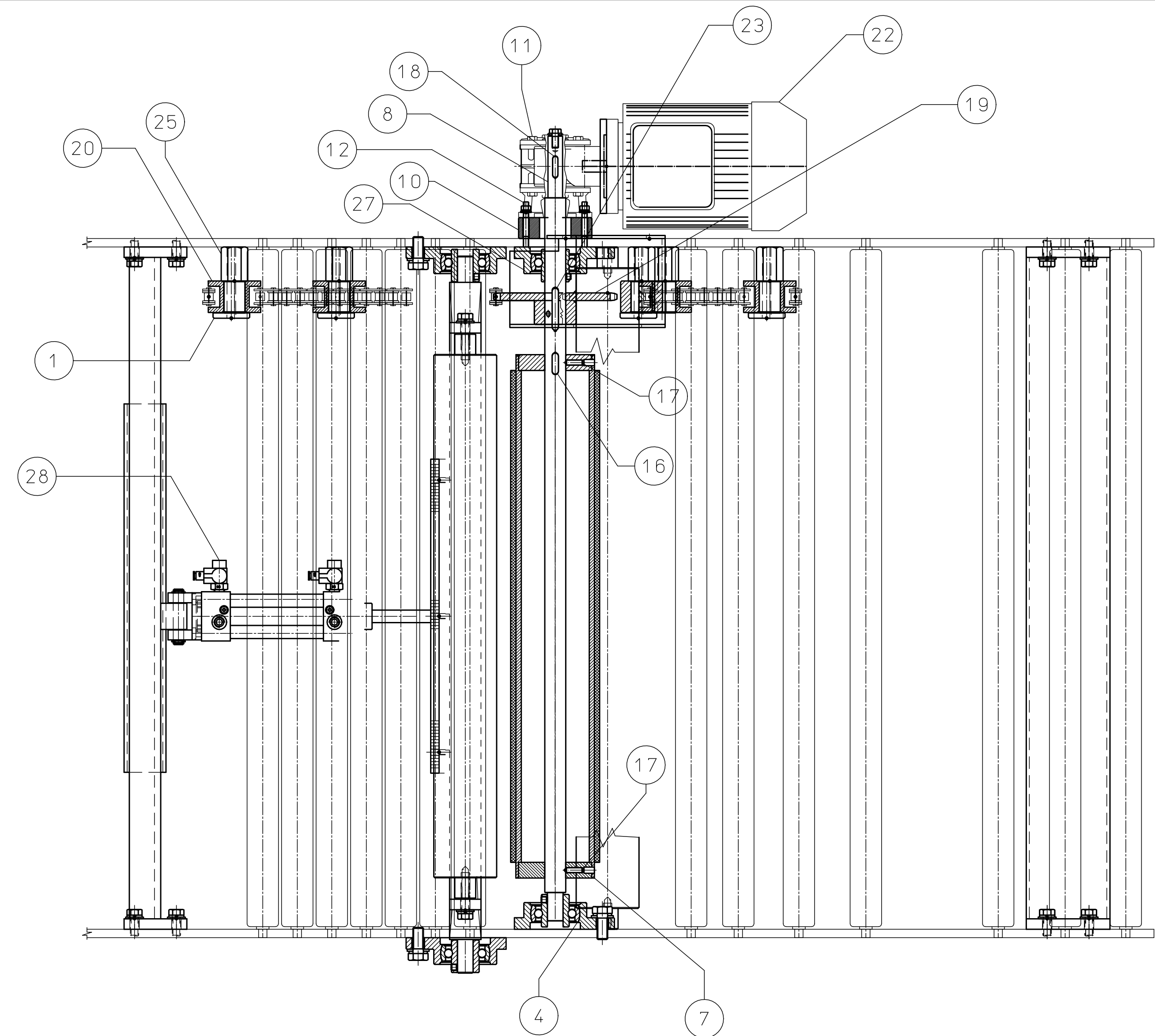

DISEGNO – DRAWING – PLAN – ZEICHNUNG – DIBUJO **M40865.03**

rif. ref. rep.	Descrizione – Description – Beschreibung – Descripción		Q.tà Q.ty Q.té Menge Cant.
1	72064.0	SUPPORT	2
2	72063.0	COLUMN	1
3	22146.0	FLOW REGULATOR, 3/8" T.8 MV380838	2
4	10320.0	SLIDE	1
5	10335.0	LINEAR GUIDE, HSR25	1
6	10283.0	LIFT PLATFORM	1
7	30593.0	KIT w/OSCILLATING PIN, FESTO ZNCM-63 ART .163528	1
8	23179.0	CLEVIS, ISO M16X1,5	1
	23180.0	PIN FOR CLEVIS, ISO M16X1,5	1
9	30799.0	CYLINDER, ISO FESTO D.63X900 DSBC-63-900-PPVA-N3 ART.1463483	1
10	72111.1	BRACKET FOR TRANSPORTATION	1
11	82078.0	LIFT STOP	1

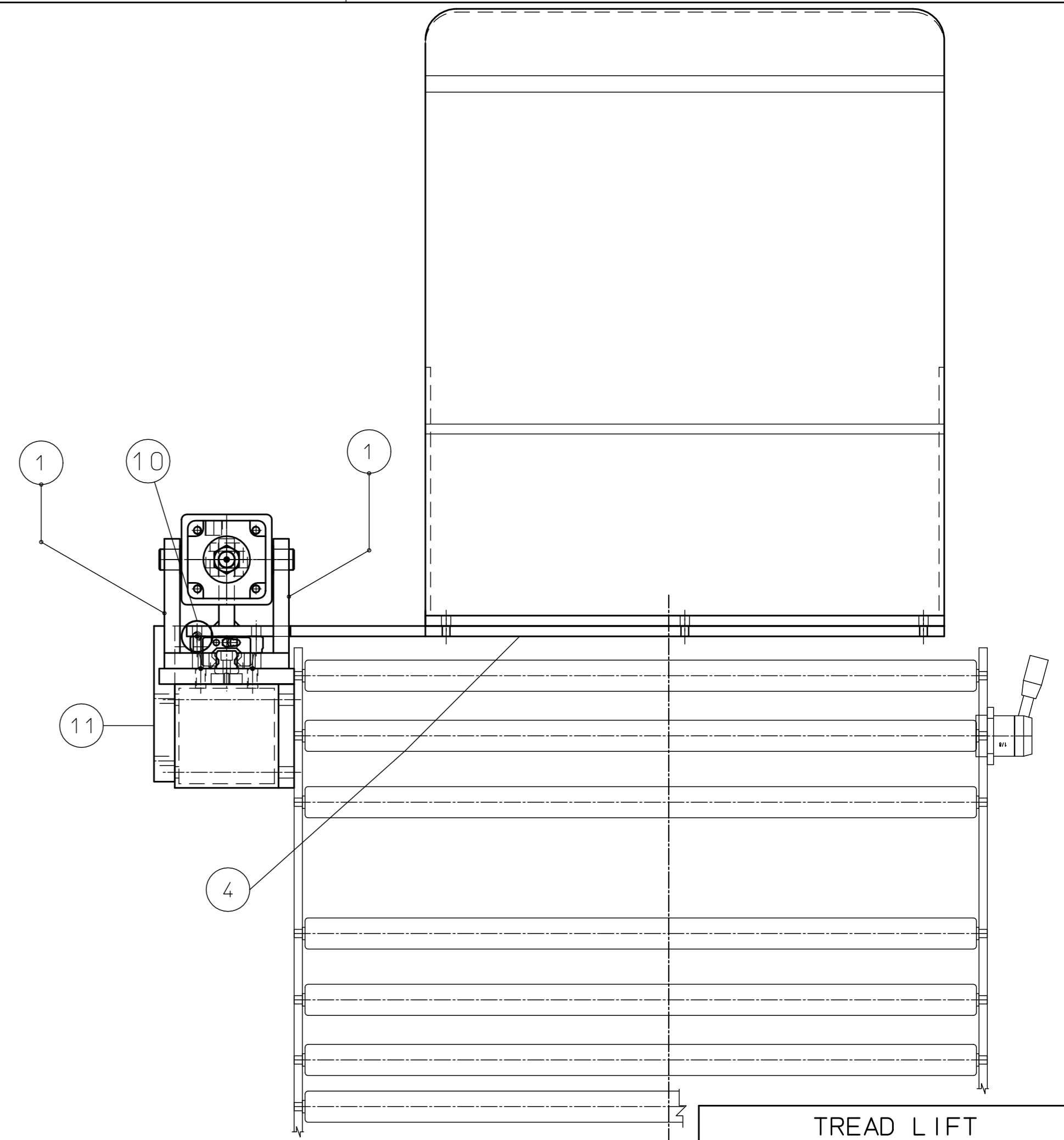
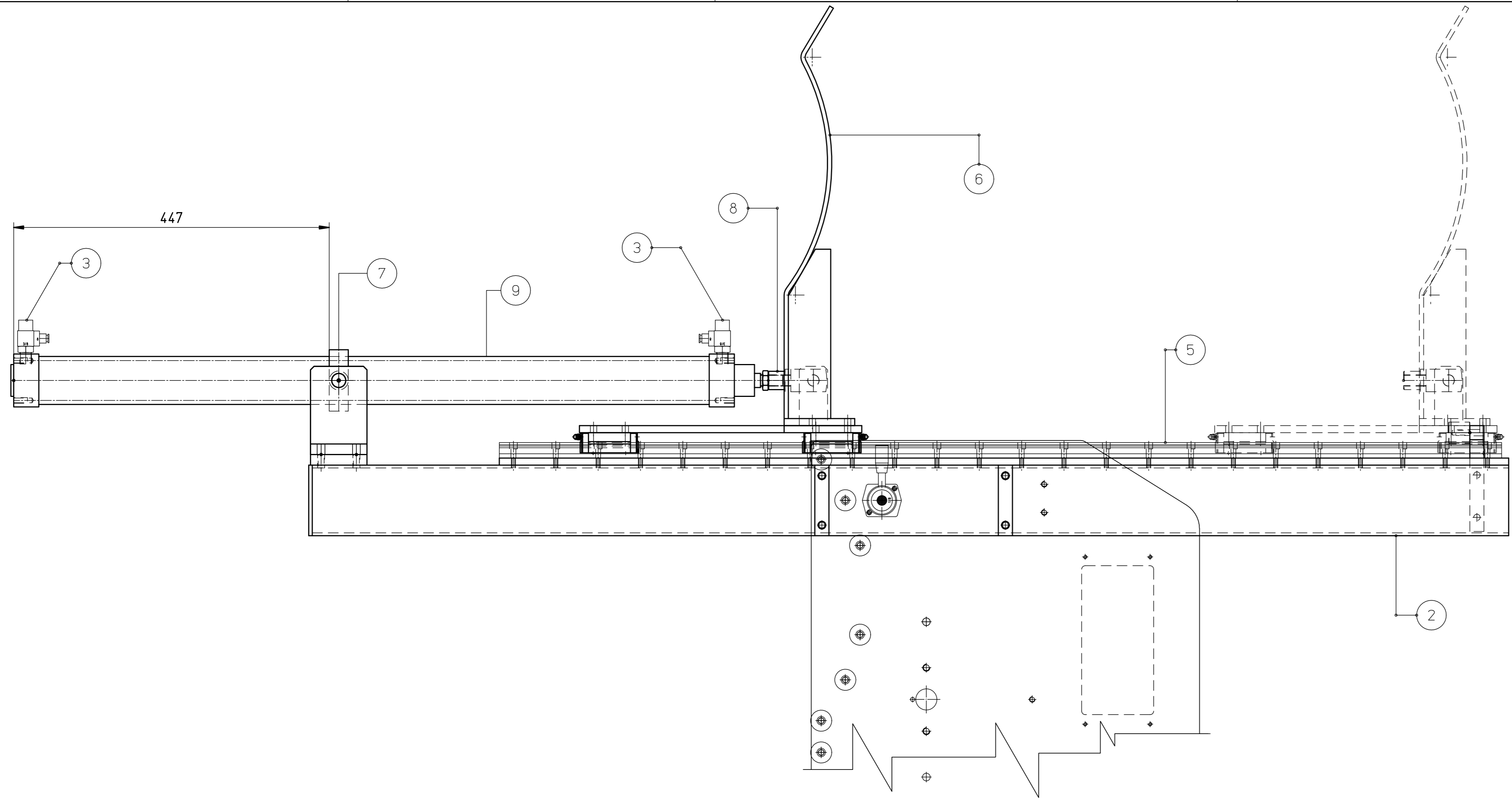

DISEGNO – DRAWING – PLAN – ZEICHNUNG – DIBUJO **M40868.03**

rif. ref. rep.	Descrizione – Description – Beschreibung – Descripción		Q.tà Q.ty Q.té Menge Cant.
1	72103.0	SCREW, TPN 20 L.H. fitment	1
2	72102.0	SUPPORT	2
3	14560.0	THREADED BUSHING, TPN 20 L.H. fitment	2
4	14510.0	THREADED BUSHING, TPN 20 R.H. fitment	2
5	72097.0	SCREW, TPN 20 R.H. fitment	2
6	72098.0	SCREW TPN, 20 L.H. fitment	1
7	10166.0	JOINT FOR BARS	2
8	85143.0	KNOB	1
9	21400.0	PILLOW BLOCK, UCFL 202	4
10	23034.0	BUSHING, 20-28-20	16
11	14481.0	BAR	4
12	21995.0	SNAP RING, I.D.25	4
13	20212.0	BALL BEARING, 6205 2RS	8
14	24039.0	NUT, I.D. 20 MM ZINC-PLATED	2
15	72094.0	ROLLER	2
16	14527.0	SHAFT MOUNT ROD	2
17	72100.0	SUPPORT, L.H. fitment	1
18	18614.0	SUPPORT	2
19	18615.0	PLATE	2
20	15871.1	PIN	8
21	20067.0	BALL BEARING, 6004 2RS	8
22	72099.0	SUPPORT, R.H. fitment	1
24	72101.0	PINION, 1/2"-5/16" Z=12	2
25	72106.0	CHAIN, 1/2"-5/16" SIMPLE L=1740	1
25	20246.0	JOINT FOR CHAIN, 1/2" S	1
26	72104.0	SPACER	2

DISEGNO – DRAWING – PLAN – ZEICHNUNG – DIBUJO **M40868.03**

rif. ref. rep.	Descrizione – Description – Beschreibung – Descripción		Q.tà Q.ty Q.té Menge Cant.
27	72105.0	SPACER	2
28	72095.0	ROLLER	2
29	20107.0	KEY, 5X5X20 UNI 6604	2
30	25385.0	WASHER RC 8	8
31	79004.0	REAR ROLLERS SPACER	2

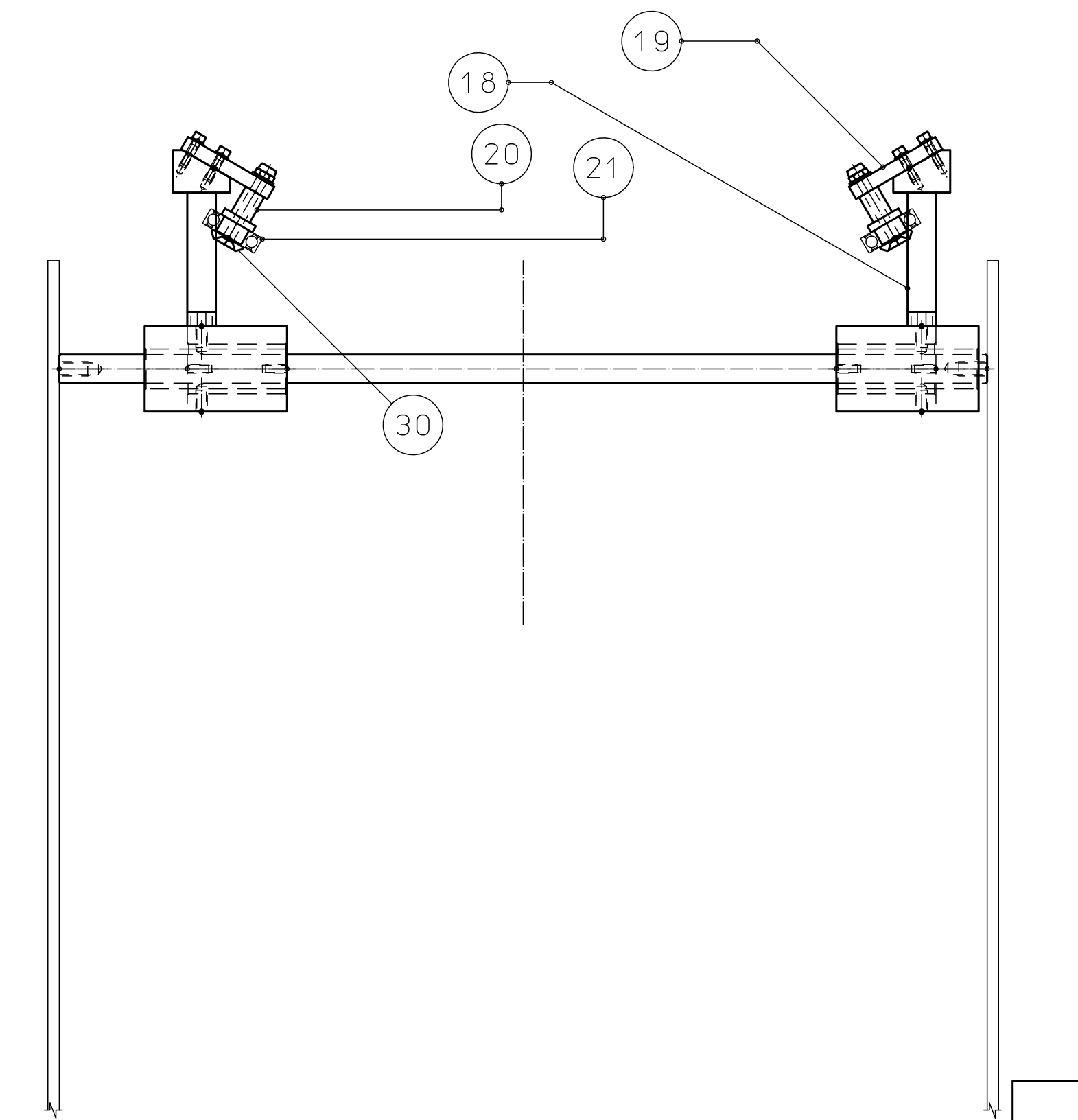
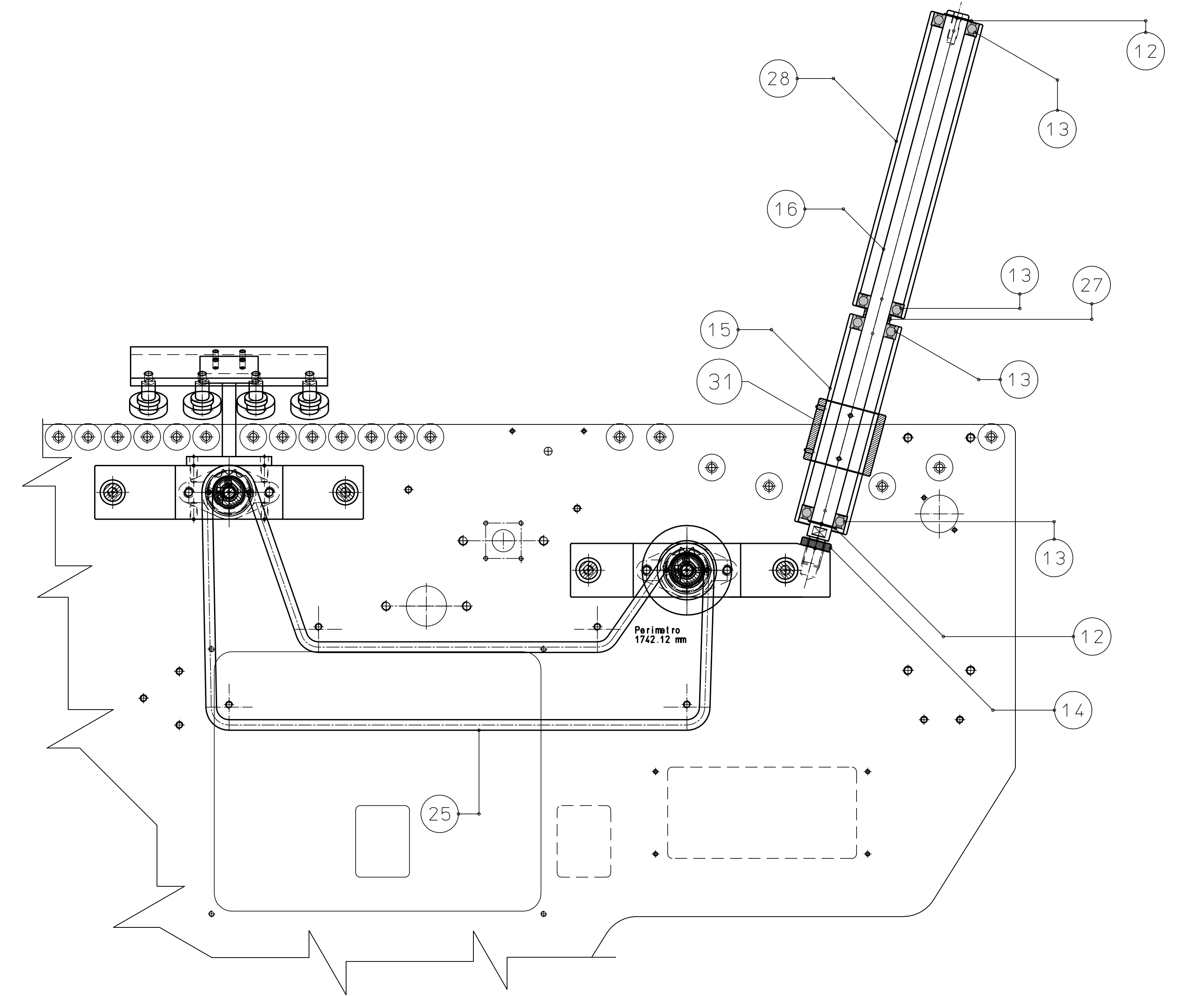
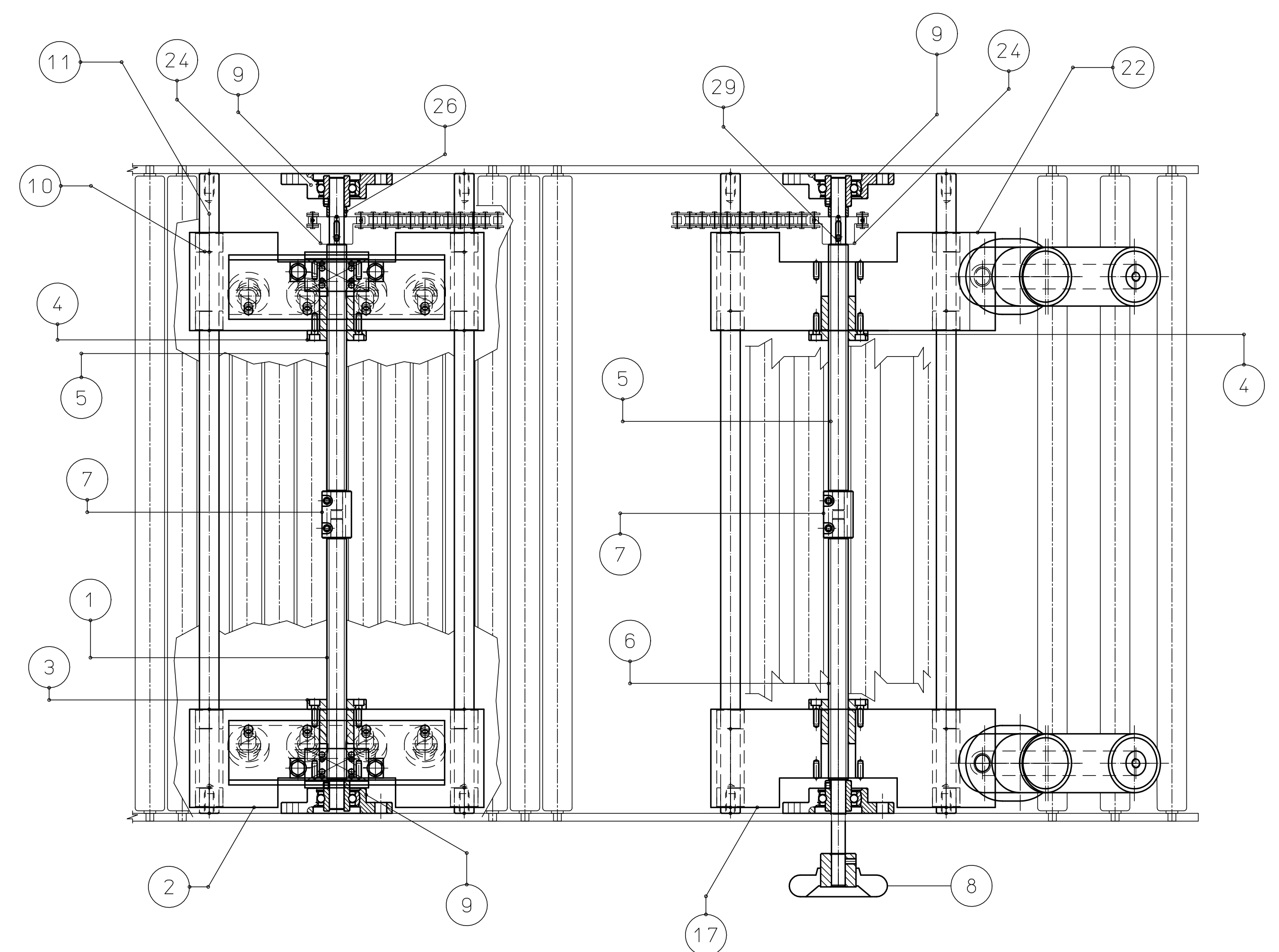

DISEGNO – DRAWING – PLAN – ZEICHNUNG – DIBUJO **M41940.07**

rif. ref. rep.	Descrizione – Description – Beschreibung – Descripción		Q.tà Q.ty Q.tè Menge Cant.
1	80646.01	CHAIN PROTECTION	1
2	14550.00	CHAIN 37 LINKS 1/2x5/16	1
3	20255-0	PIN UNI 6364 d6x14	1
4	20246-0	LINK FOR CHAIN 1/2 S	2
5	14542.02	PLATE	1
6	14549.01	CHAIN 31 LINKS 1/2x5/16	1
7	22758-0	KEY 8x7X80	1
8	14543.01	EXTENSION	1
9	14503.01	RACK FRONT PROTECTION	1
10	21012-0	WASHER di8.5 De35 Sp.5	1
11	32842-0	GEARBOX RMI70FL 1/80 PAM80 B14	1
12	83184.00	SHAFT	1
13	83186.00	PIN FOR ROTARY CUTTER WHEEL	2
14	20069-0	BALL BEARING 15x32x9 SKF 6002-2RS1	8
15	83187.00	WHEEL ECCENTRIC PIN	2
16	83194.00	SUPPORT	1
17	14530.00	PROXIMITY SUPPORT	1
18	83185.00	CUTTER RACK	1
19	14544.00	WHEEL	2
20	14440.00	FRAME	1
21	22175-0	SEEGER RING E 15	4
22	22711-0	CONNECTOR	2
23	14547.00	LINEAR GUIDE	1
24	21934-0	SNAP RING UNI 7437 32	8
25	22708-0	PROXIMITY M12	2
26	14468.01	SHIM	1
27	2171-0.00	FEELER	1
29	20728-0	MOTOR, SELF BRAKEING MA80 4P 1HP B14	1
30	20212-0	BALL BEARING 25x52x15 SKF 6205-2RS1	4
31	21967-0	KEY 5x5x10	1

DISEGNO – DRAWING – PLAN – ZEICHNUNG – DIBUJO **M41940.07**

rif. ref. rep.	Descrizione – Description – Beschreibung – Descripción		Q.tà Q.ty Q.tè Menge Cant.
32	14460.00	IDLE PINION	1
33	14464.00	SPACER	1
34	14466.00	SPACER	1
35	14456.00	FLANGE	1
36	83188.00	SHAFT	1
37	11316-0.00	FLANGE	1
38	79407.01	COVER	1
39	2520.00	BLADE	1
40	83465.01	PROTECTION	1
41	20686-0	SEEGER RING E 17	2
42	21816-0	SNAP RING UNI 7437 35	2
43	25370-0	LIMIT SWITCH SIEMENS 3SE5-112-0CD02 (EX 3SE2-120-1D)	1
44	21276-0	BALL BEARING 6003 2RS	4
45	14442.00	PINION	1
46	14459.00	PINION	1
47	14467.00	PIN	2
48	20252-0	KEY 6x6x20 UNI 6604	1
49	14465.00	SPACER	1
50	20916-0	WASHER RGS 10-35	1
51	14463.01	MOTORIZED PINION	1
52	14443.00	SPACER	1
53	14444.00	FLANGE	1
54	83182.00	RACK	1
55	83183.01	GEAR Z=19 MODULE 4	1
56	22039-0	CONNECTING LINK 1/2" SIMPLE	1
57	83277.00	LOWER WHEEL	2
60	24042-0	SCREW, COUNTERSUNK HEXAGONAL HEAD M6X60 UNI5933 ZINC – COATED	1

DISEGNO – DRAWING – PLAN – ZEICHNUNG – DIBUJO **M41940.07**

rif. ref. rep.	Descrizione – Description – Beschreibung – Descripción			Q.tà Q.ty Q.tè Menge Cant.
61	23879-0	SCREW, HEXAGONAL HEAD. M10X20 UNI5739 ZINC – COATED		1
62	83278.00	LOWER LINEAR GUIDE		1
63	23691-0	SCREW, HEXAGONAL HEAD M10X60 UNI5739 ZINC – COATED		6
64	23850-0	SCREW, HEXAGONAL HEAD M8X40 UNI5931 ZINC – COATED		3
65	24974-0	SCREW, HEXAGONAL HEAD M5X20 UNI5931 ZINC - COATED		12
66	23882-0	SCREW, HEXAGONAL HEAD M5X16 UNI5931 ZINC - COATED		12
69	83658.00	WASHER		2
70	83657.00	LOCKING GUIDE		2
71	25757-0	HEX. NUT M14 UNI 5589		2
72	83655.00	FRAME		2
73	83656.01	BLOCK		1
74	24709-0	SCREW, COUNTERSUNK HEXAGONAL HEAD M8X20 UNI5931 ZINC - COATED		6
75	23739-0	WASHER SCHNORR D.8		6
76	23643-0	SCREW, HEXAGONAL HEAD M8X30 UNI5739 ZINC - COATED		2
77	25734-0	WASHER NORD LOCK NL8 I		2
78	24887-0	SCREW, HEXAGONAL HEAD M8X45 UNI5739 ZINC - COATED		4
79	23845-0	HEXAGONAL NUT M8 UNI5588 ZINC - COATED		4
80	23689-0	SCREW, HEXAGONAL HEAD M10X40 UNI5739 ZINC - COATED		1
81	23862-0	HEXAGONAL NUT M10 UNI5588 ZINC - COATED		1
82	24909-0	SCREW, HEXAGONAL SOCKED COUNTERSUNK FLAT HEAD M5X20 UNI5927 P.C.		1

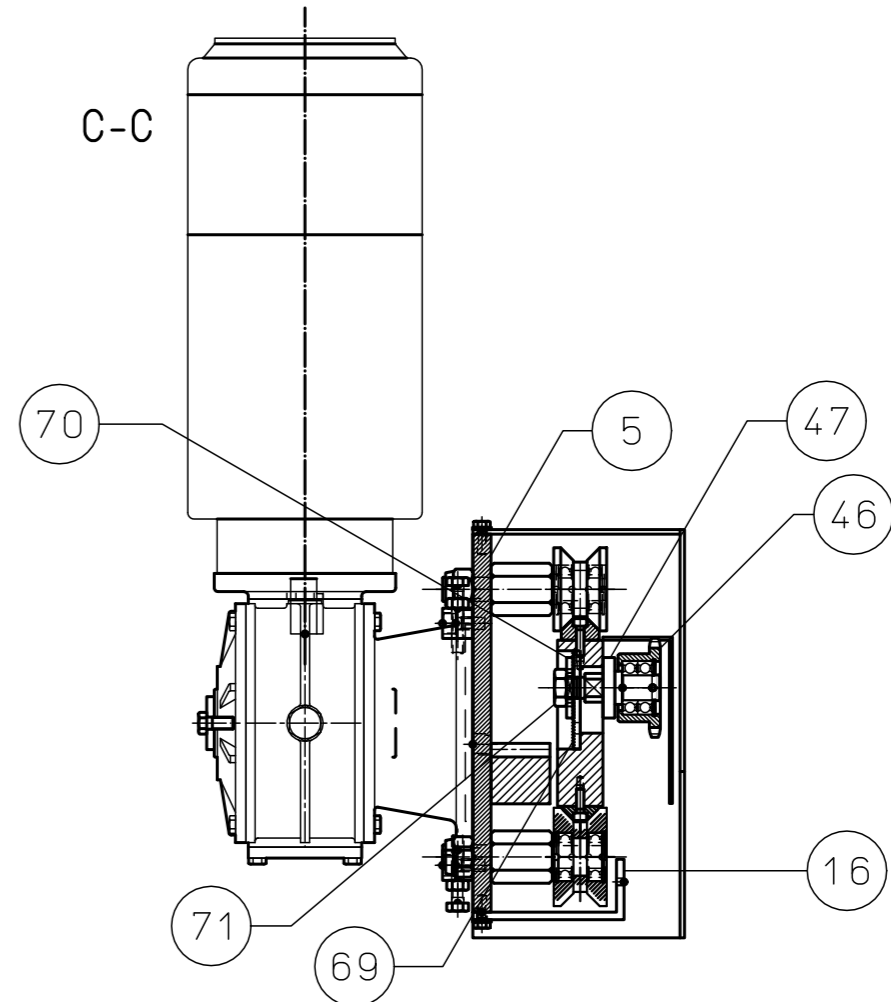
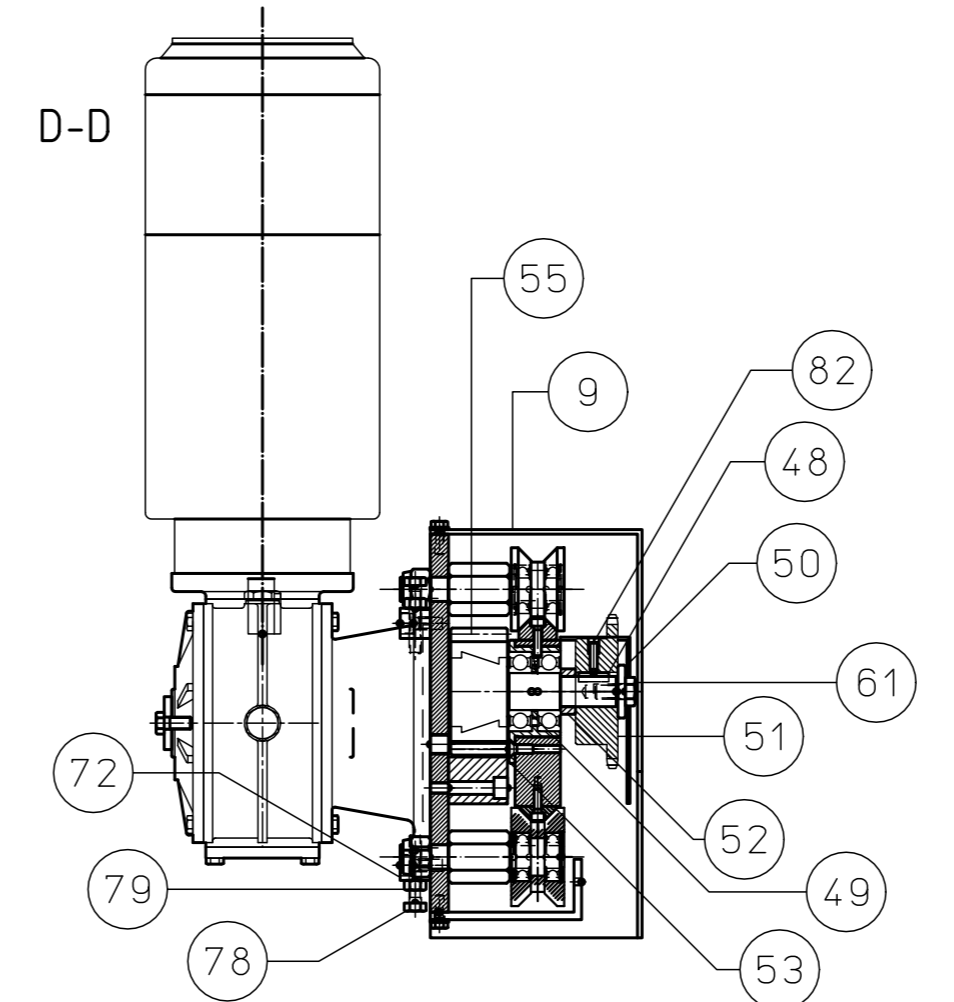
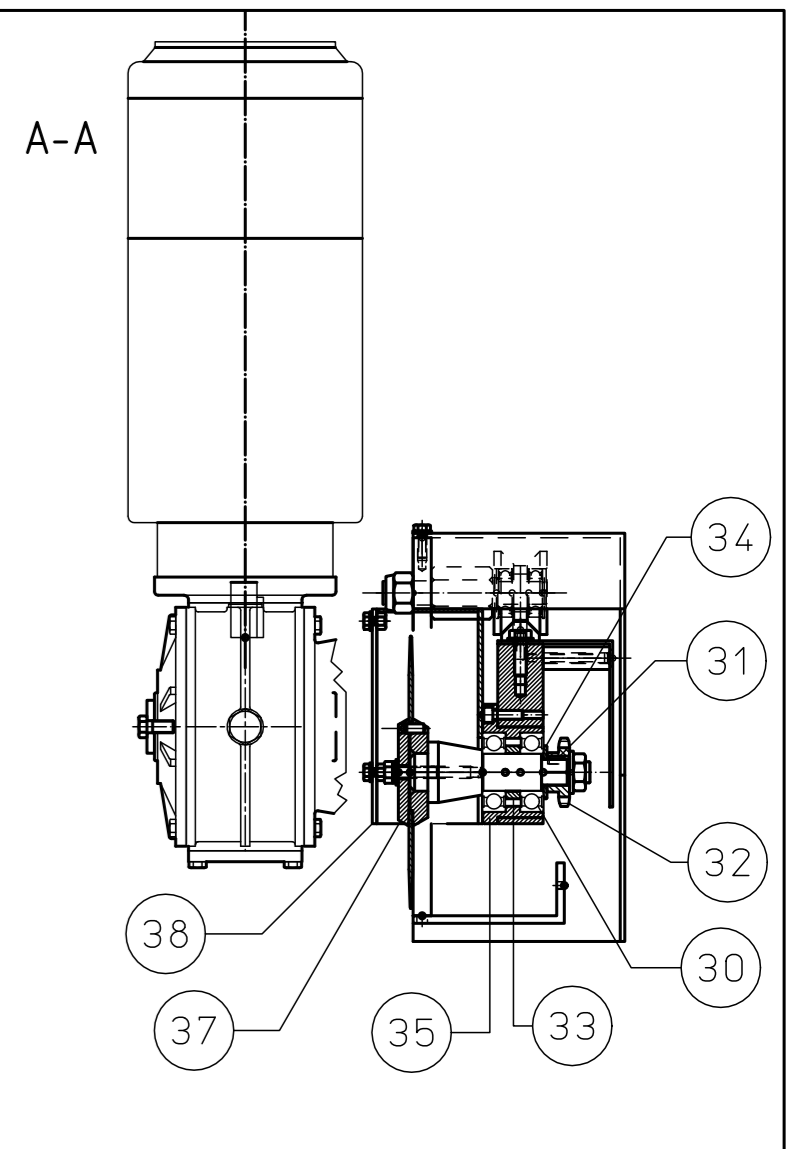
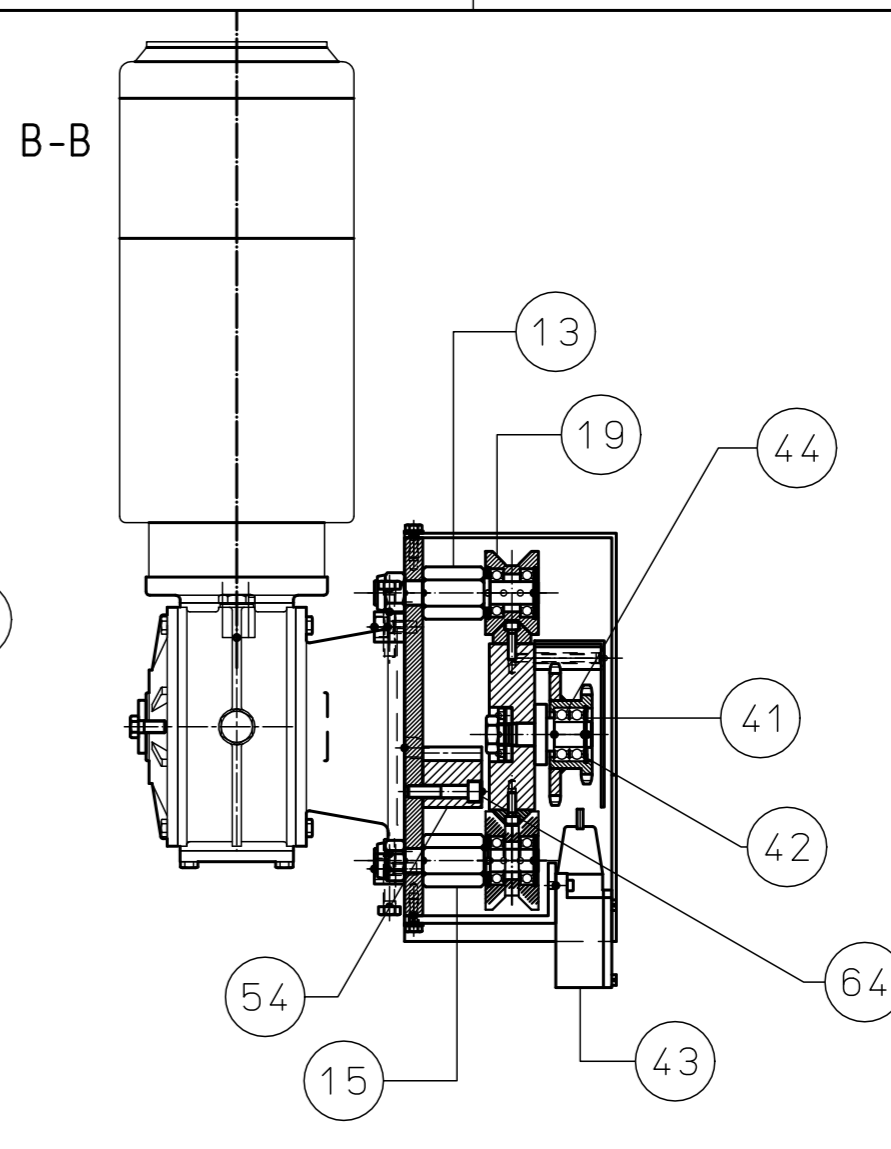
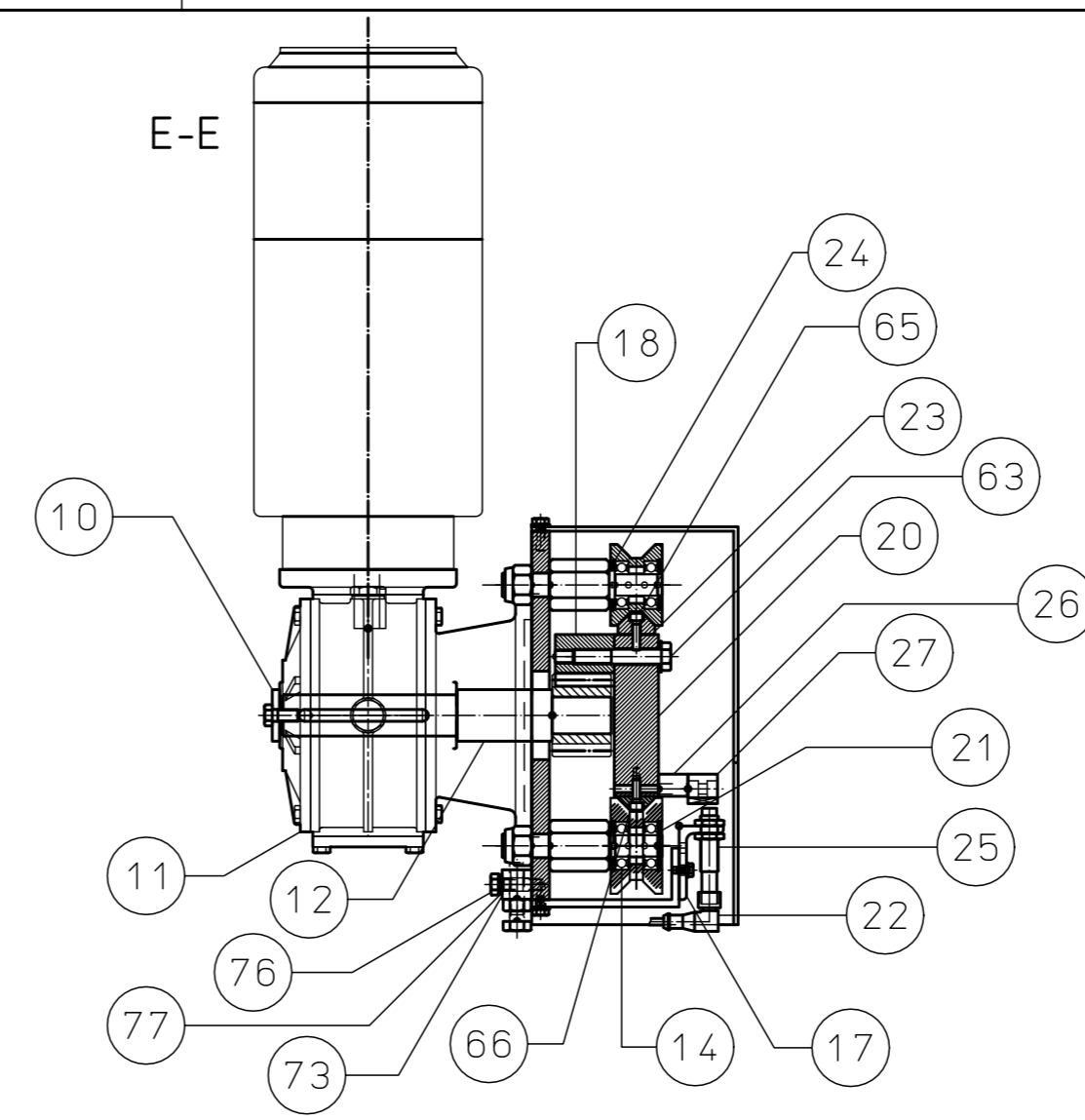
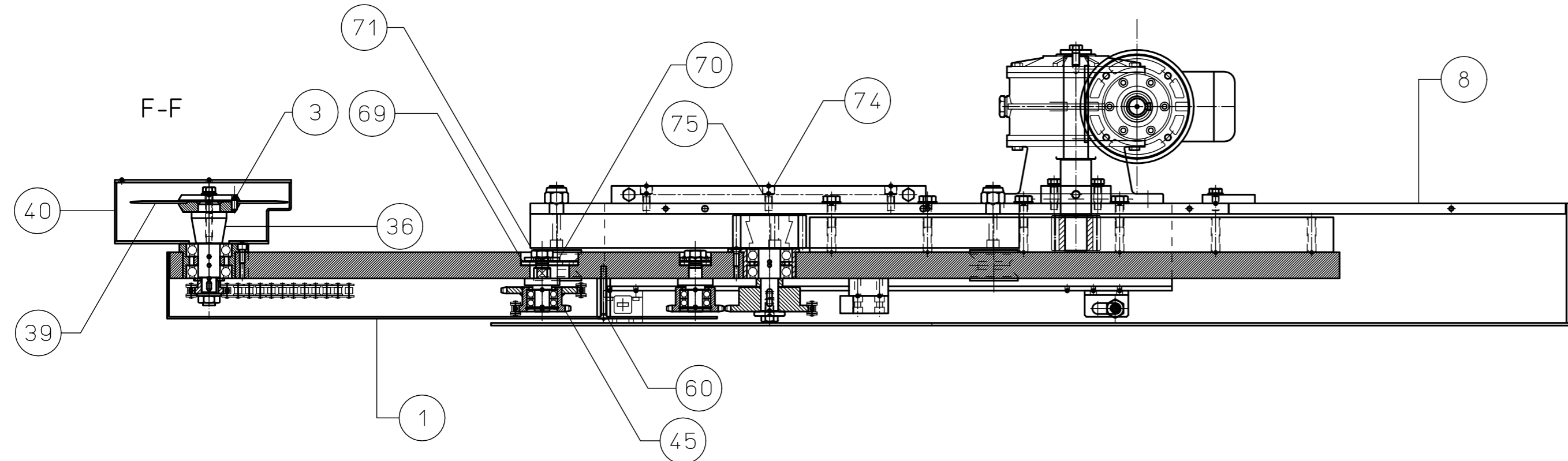
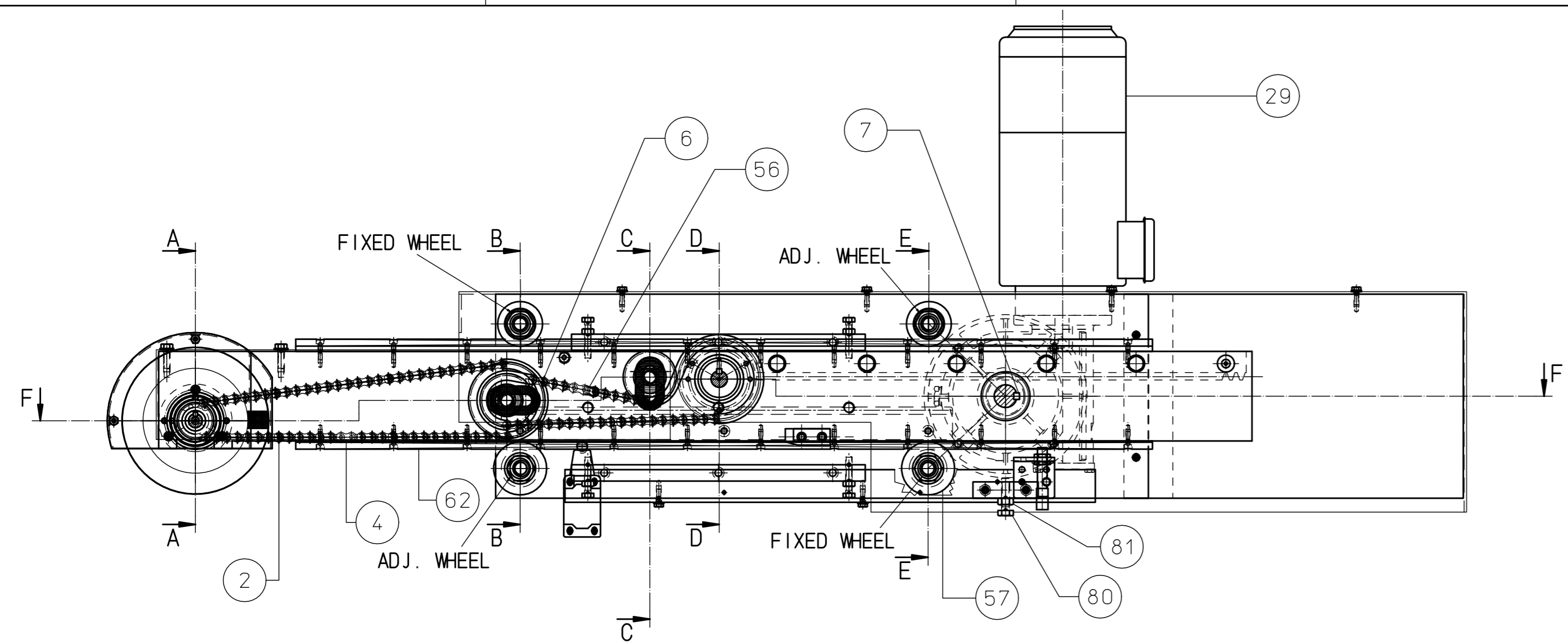

VALE DA MAT-21115

DISEGNO – DRAWING – PLAN – ZEICHNUNG – DIBUJO **M42220.01**

rif. ref. rep.	Descrizione – Description – Beschreibung – Descripción		Q.tà Q.ty Q.tè Menge Cant.
1	14483.3	COLUMN	1
2	14478.0	PIN	1
3	27839.0	HINGE, MALE NORGREN D.80 QA/8080/27	1
4	29049.0	CYLINDER, ISO FESTO D.80X150 DNCB-80 150-PPV-A	1
5	22485.0	ROD EYE, GIKFR 20 PB M20X1,5 R.H. fitment	1
6	14480.0	BAR	3
7	14482.0	TABLE	1
8	86204.00	CONTROL PANEL SUPPORT	1
9	14447.0	TRAY	1
11	14448.0	SUPPORT FOR TRANSPORT PURPOSES	1
12	14517.5	PLATE	1
13	22227.1	ROLLER, ALFA 32/10 B3 X597 Y603 Z623 STAINLESS STEEL 304 W/PIN	2
14	72065.0	SUPPORT	2
15	20538.0	VALVE, 1/8" 4001I	1
16	72081.0	SPACER FOR ROLLER	1
17	28006.0	PHOTOCELL, BALLUFF BOS18KFPA1QDS4C	1
18	72078.02	ROLLER RULMECA 111/28 8D 30I 253 (ROLLER D.30x1.2 STAINLESS STEEL/AXIS D.8, W/SPRING) C=253 A=269 B=249	2
19	72079.02	ROLLER RULMECA 111/28 8D 30I 652 (ROLLER D.30x1.2 STAINLESS STEEL/AXIS D.8 W/SPRING) C=652 A=668 B=648	22
20	86205.01	FRAME	1
	72060-0	FRAME	1
	86207.00	FRAME EXTENSION	1
21	14548.0	SPACER	2
22	72061.1	PLATE, FRONT fitment	1
23	72062.1	PLATE, REAR fitment	1

DISEGNO – DRAWING – PLAN – ZEICHNUNG – DIBUJO **M42220.01**

rif. ref. rep.	Descrizione – Description – Beschreibung – Descripción		Q.tà Q.ty Q.tè Menge Cant.
24	80313.0	SUPPORT	1
25	20655.0	QUICK EXHAUST VALVE, 1/4" VSC544	1
26	25461.0	PRESSURE GAUGE, D.40 1/8" POS. 0-6 bar	5
27	24604.0	PRESSURE REGULATOR, 3/8" 0-4BAR	1
28	27364.0	PRESSURE GAUGE, D.63 1/4" POS.0-12 bar	1
29	27363.0	PRESSURE GAUGE, D.50 1/4" POS.0-4 bar	1
31	20426.0	PIN, D.16X55	3
32	20559.0	FITTING, STRAIGHT MALE 3/8"-M 1/4"	1
33	72082.0	PROTECTION FOR PRESSURE GAUGES	1
34	25776.0	PRESSURE REG., 1/4" w/quick exhaust MR39 1/4" R8SRU	5
35	23226.0	PRESSURE GAUGE, 50 1/8" POST. 0-12	1
36	27305.0	FILTER REGULATOR NORGREN, 1/2" B73G-4GK-SP3-SP	1
37	27849.0	LOCKABLE VALVE, 1/2" NORGREN T73T-4GA-P1N	1
39	22858.0	FITTING, ELBOW CONNECTOR MF 1/2"	2
40	22240.0	FITTING, T-SHAPED MF F G 1/2"	1
42	20806.0	FITTING, M3/8" (410/2E)	1
43	20510.0	NIPPLE, M1/2"-F3/8"	2
44	20428.0	FITTING, MALE ELBOW 1/2	1
45	29495.0	CLAMP W/BRACKET, NORGREN 431452	1
46	21931.0	FITTING, STRAIGHT CONNECTOR, M 3/8"	1
47	27742.0	SUBBASE, CQM/22152/3/21 NORGREN	5
48	27743.0	TERMINAL FOR SOLENOID VALVE, CQM/22152/3/22	1
49	27365.0	SOLENOID VALVE, NORGREN 5/3 CC SXE 9673-A	1
50	27366.0	SOLENOID VALVE, NORGREN 5/2 SXE 9573-Z70-	4
51	21567.0	CYLINDER, ISO UNIVER D.80X150	7
52	26748.0	COIL, NORGREN QM/48/13J/21 24VDC	7

DISEGNO – DRAWING – PLAN – ZEICHNUNG – DIBUJO **M42220.01**

rif. ref. rep.	Descrizione – Description – Beschreibung – Descripción		Q.tà Q.ty Q.tè Menge Cant.
53	20339.0	FITTING, 3/8" MALE TO MALE ADAPTER	1
54	27264.0	SOLENOID VALVE, NORGREN 3/2 V62C423A-A2000	1
57	24442.0	PRESSURE GAUGE, D.40 1/8" POST. 0-12 BAR	1
58	22146.0	FLOW REGULATOR, 3/8" DIA. 8 HOSE (453080)	2
59	21177.0	FLOW REGULATOR, DIRFU14/0	1
60	22932.0	VALVE, ONE-WAY, 1/2" 06VFU2	1
61	29578-2	ROLLER RULMECA GL/62 12R 32I 652 (ROLLER D.32x1.5 STAINLESS STEEL/AXIS D.12 HOLE M8x15) C=652 A=652 B=626	6
62	31591-0	CONNECTOR+CABLE BALLUFF C12F-4B2-10K0	1
63	24511-3	REFLECTOR R6 60X40,5mm.	1
64	80308-0	PHOTOCELL SUPPORT	1
65	81510-0	SUPPORT	1
66	83671.00	FRAME	1
67	80060.00	WASHER	1

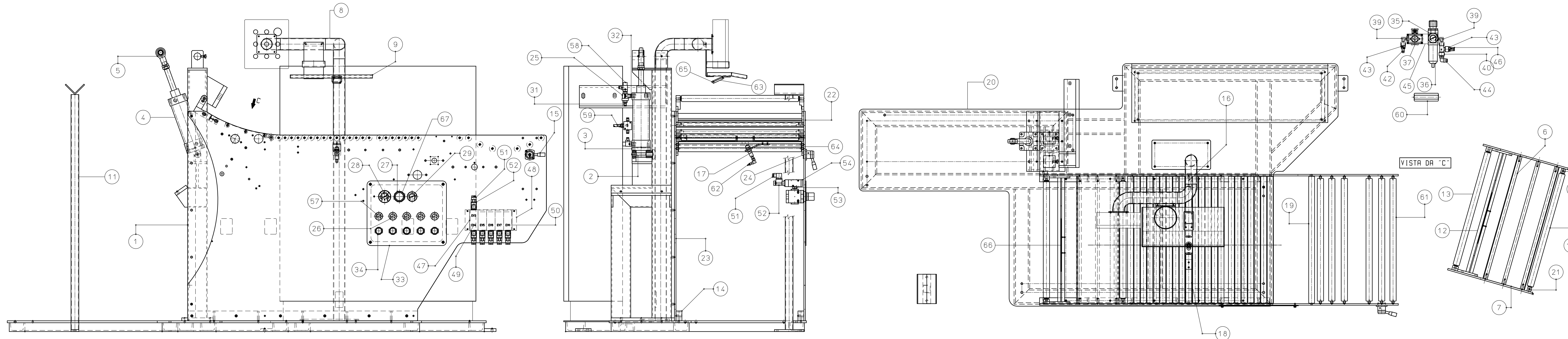

VISTA DA "C"

*lista dei componenti e
schema elettrico*

*electrical part list
and diagram*

*description des composants
et schéma électrique*

*Elektroteile-Liste und
elektrischer Schaltplan*

*lista de los componentes y
esquema eléctrico*



matteuzzi srl

VIA SERRA 1/E
40012 CALDERARA DI RENO
BOLOGNA, ITALY

TEL. ++39 051 726351
FAX ++39 051 726283
www.matteuzzi-srl.com
matteuzzi@matteuzzi-srl.com

Company / customer	Matteuzzi Srl
Project description	RAS 405 UL
Drawing number	MEC 5693.1
Commission	/
Project name	5693_1
Make	Matteuzzi srl
Responsible for project	Matteuzzi srl
Type	/
Place of installation	/

VOLTAGE = 480 Y / 277 VAC
 PHASE = 3 + GND 4 WIRES
 FREQUENCY = 60 Hz
 TOTAL FLA = 6,88 A
 LARGEST MOTOR FLA = 2,2 A
 SCCR = 10KA RMS SYM AT 480V
 MACHINE TYPE (ENVIRONMENT) = 1
 ENCLOSURE TYPE = 12
 FIELD WIRING DIAGRAM = 5693.1

INDUSTRIAL CONTROL PANEL FOR INDUSTRIAL MACHINERY
 SHORT CIRCUIT CURRENT RATING OF THE PROTECTIVE DEVICE = 25KA

Created on	16/07/2020
Revision	Rev_00

REV.	MODIFY	DATE	SIGN

Drawn	MATTEUZZI	Job	MEC 5693.1
Verified	MATTEUZZI	File Name	5693_1
Customer	MATTEUZZI	Date	16/07/2020

Title	INTESTAZIONE	SHEET 1
	HEADING	
Plant	POWER AND AUXILIARY RAS 405 UL	NEXT 2

IEC Sym.	JIC Sym.	Descrizione\Description
K 	CR 	RELAY COIL
Q 	CON 	CONTACTOR COIL
X 	PL 	PLUG
M 	SOL 	ELECTROMECHANICAL ACTUATOR
T 	T 	THREE PHASE TRANSFORMER
T 	T 	SINGLE PHASE TRANSFORMER
M 	MTR 	THREE PHASE MOTOR
C 	CAP 	CAPACITOR
M 	SOL 	SOLENOID VALVE
R 	RES 	RESISTOR
E 	MTR 	ELECTROBLOWING FAN

IEC Sym.	JIC Sym.	Descrizione\Description
P 	LT 	LAMP
S 	PB 	PUSH BUTTON NO
S 	PB 	PUSH BUTTON NC
S 	PB 	EMERGENCY PUSH BUTTON NC
S 	LS 	LIMIT SWITCH NO (NOT OPERATED)
S 	SS 	TWO POSITION SWITCH
K 	CR 	RELAY NO CONTACT
K 	CR 	RELAY NC CONTACT
Q 	CON 	CONTACTOR NO CONTACT
Q 	CON 	CONTACTOR NC CONTACT
Q 	CB 	SINGLE POLE MAGNETIC THERMIC SWITCH

IEC Sym.	JIC Sym.	Descrizione\Description
Q 	CB 	TWO POLE MAGNETIC THERMIC SWITCH
Q 	CB 	THREE POLE MAGNETIC THERMIC SWITCH
F 	FU 	SINGLE POLE FUSE
F 	FU 	TWO POLE FUSE
F 	FU 	THREE POLE FUSE
B 	PRS 	PROXIMITY NO
B 	PRS 	PHOTOCELL NO
G 	PWS 	POWER SUPPLY
V 	REC 	BRIDGE DIODES

LISTA FOGLI \ INDEX

Foglio Sheet	Descrizione Description	Foglio Sheet	Descrizione Description
1	INTESTAZIONE / HEADING		
2	TABELLA CONVERSIONE SIMBOLI / SYMBOL CONVERSION TABLE		
3	LEGENDA FOGLI / LIST OF PAGES		
10	ARRIVO LINEA / POWER SUPPLY		
20	ALIMENTAZIONE 24VDC / SUPPLY 24VDC		
30	MOTORI PARTENZA DIRETTA / DIRECT START MOTOR		
31	MOTORI PARTENZA DIRETTA / DIRECT START MOTOR		
32	MOTORI PARTENZA DIRETTA / DIRECT START MOTOR		
41	INVERTER GRUPPO RULLATURA / STITCHING GROUP INVERTER		
42	INVERTER POLY / POLY INVERTER		
70	AUSILIARI 24VDC / AUXILIARY 24VDC		
71	AUSILIARI 24VDC / AUXILIARY 24VDC		
90	CATENA EMERGENZA / EMERGENCY LINE		
91	EMERGENZA / EMERGENCY		
92	EMERGENZA / EMERGENCY		
95	SICUREZZA COMANDO A DUE MANI / BI-MANUAL COMMAND SAFETY DEVICE		
100	RACK PLC / PLC RACK		
110	INPUT DIGITALI / DIGITAL INPUTS		
111	INPUT DIGITALI / DIGITAL INPUTS		
112	INPUT DIGITALI / DIGITAL INPUTS		
113	INPUT DIGITALI / DIGITAL INPUTS		
114	INPUT DIGITALI / DIGITAL INPUTS		
130	OUTPUT DIGITALI / DIGITAL OUTPUTS		
131	OUTPUT DIGITALI / DIGITAL OUTPUTS		
132	OUTPUT DIGITALI / DIGITAL OUTPUTS		
133	OUTPUT DIGITALI / DIGITAL OUTPUTS		
150	INPUT ANALOGICI / ANALOG INPUTS		
800	MORSETTIERE XT0 E XT1 / TERMINALS XT0 E XT1		
801	MORSETTIERA XT2 / TERMINALS XT2		
900	LAYOUT QE RAS 405 UL / RAS 405 UL LAYOUT QE		
902	PANNELLO COMANDI / CONTROL PANEL LAYOUT		

Note :



REV.	MODIFY	DATE	SIGN

Drawn	MATTEUZZI	Job	MEC 5693.1
Verified	MATTEUZZI	File Name	5693_1
Customer	MATTEUZZI	Date	16/07/2020

Title	LEGENDA FOGLI LIST OF PAGES	SHEET	3
Plant	POWER AND AUXILIARY RAS 405 UL	NEXT	10

ARRIVO LINEA
480V 60Hz 3P+T
INCOMING LINE
480V 60Hz 3P+T

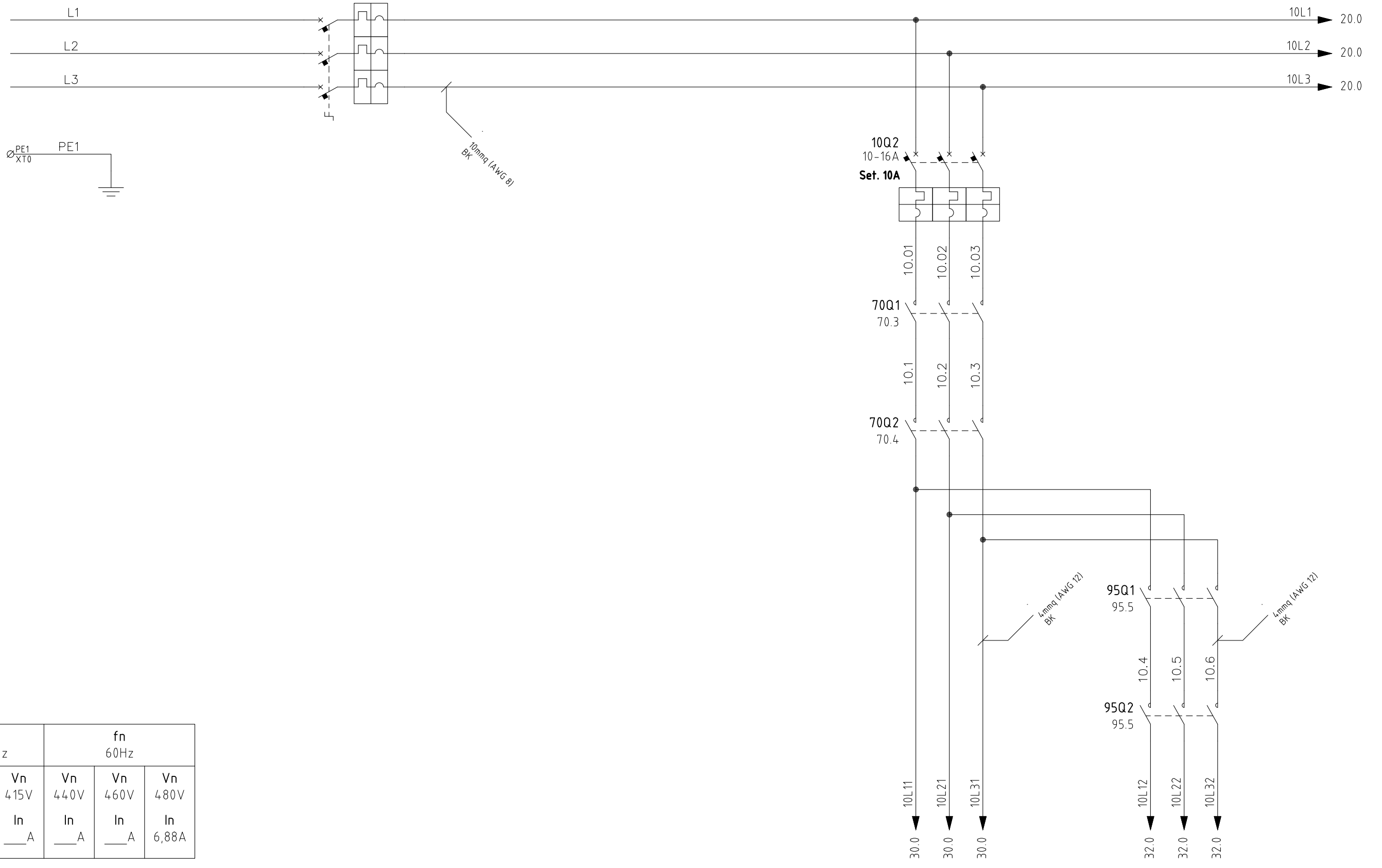

P 5,7kW	fn 50Hz		fn 60Hz		
	Vn 400V	Vn 415V	Vn 440V	Vn 460V	Vn 480V
	In ___A	In ___A	In ___A	In ___A	In 6,88A



matteuzzi srl
Calderara di Reno
(BO) ITALY

REV.	MODIFY	DATE	SIGN
------	--------	------	------

Drawn	MATTEUZZI	Job	MEC 5693.1
Verified	MATTEUZZI	File Name	5693_1
Customer	MATTEUZZI	Date	16/07/2020

Title	ARRIVO LINEA POWER SUPPLY	SHEET	10
Plant	POWER AND AUXILIARY RAS 405 UL	NEXT	20

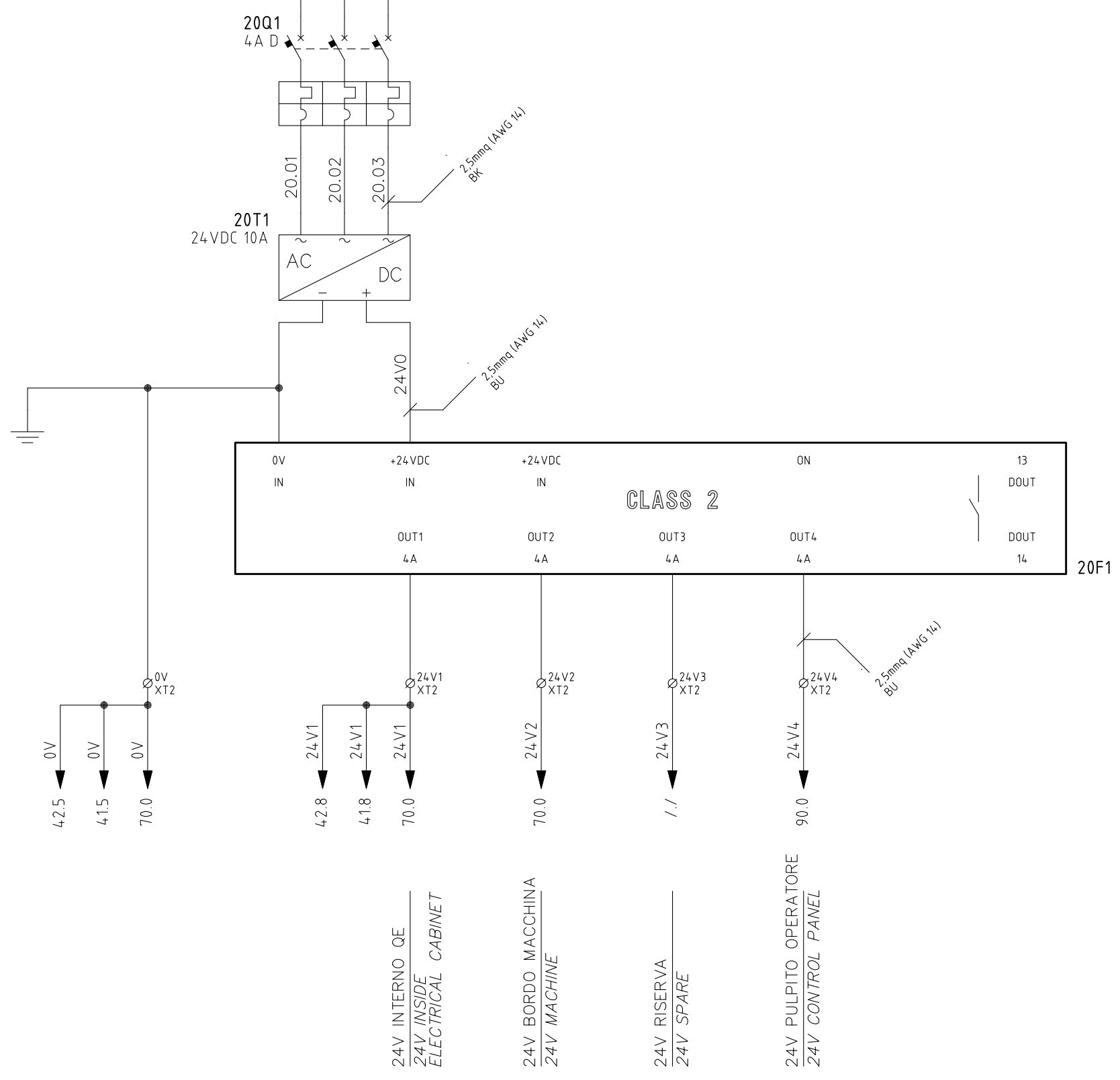
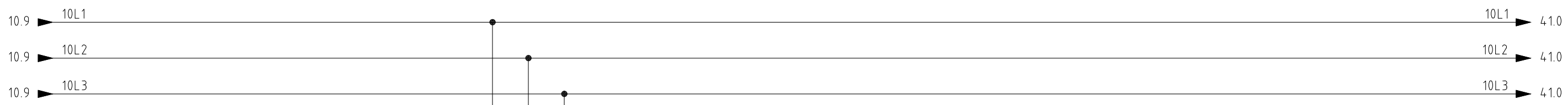

REV.	MODIFY	DATE	SIGN

Drawn	MATTEUZZI	Job	MEC 5693.1
Verified	MATTEUZZI	File Name	5693_1
Customer	MATTEUZZI	Date	16/07/2020

Title	ALIMENTAZIONE 24VDC SUPPLY 24VDC	SHEET	20
Plant	POWER AND AUXILIARY RAS 405 UL	NEXT	30

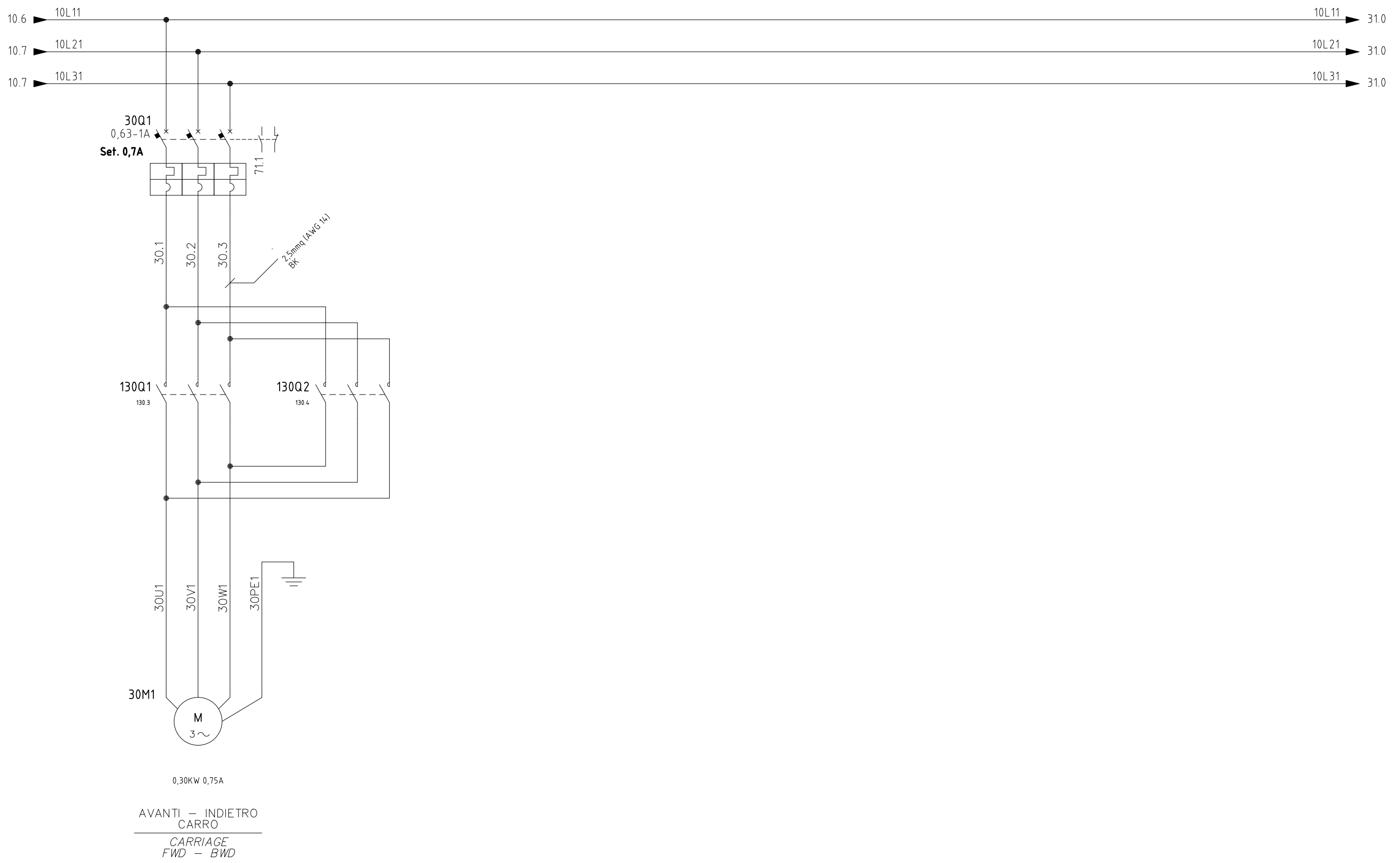

REV.	MODIFY	DATE	SIGN

Drawn	MATTEUZZI	Job	MEC 5693.1
Verified	MATTEUZZI	File Name	5693_1
Customer	MATTEUZZI	Date	16/07/2020

Title	MOTORI PARTENZA DIRETTA DIRECT START MOTOR	SHEET	30
Plant	POWER AND AUXILIARY RAS 405 UL	NEXT	31

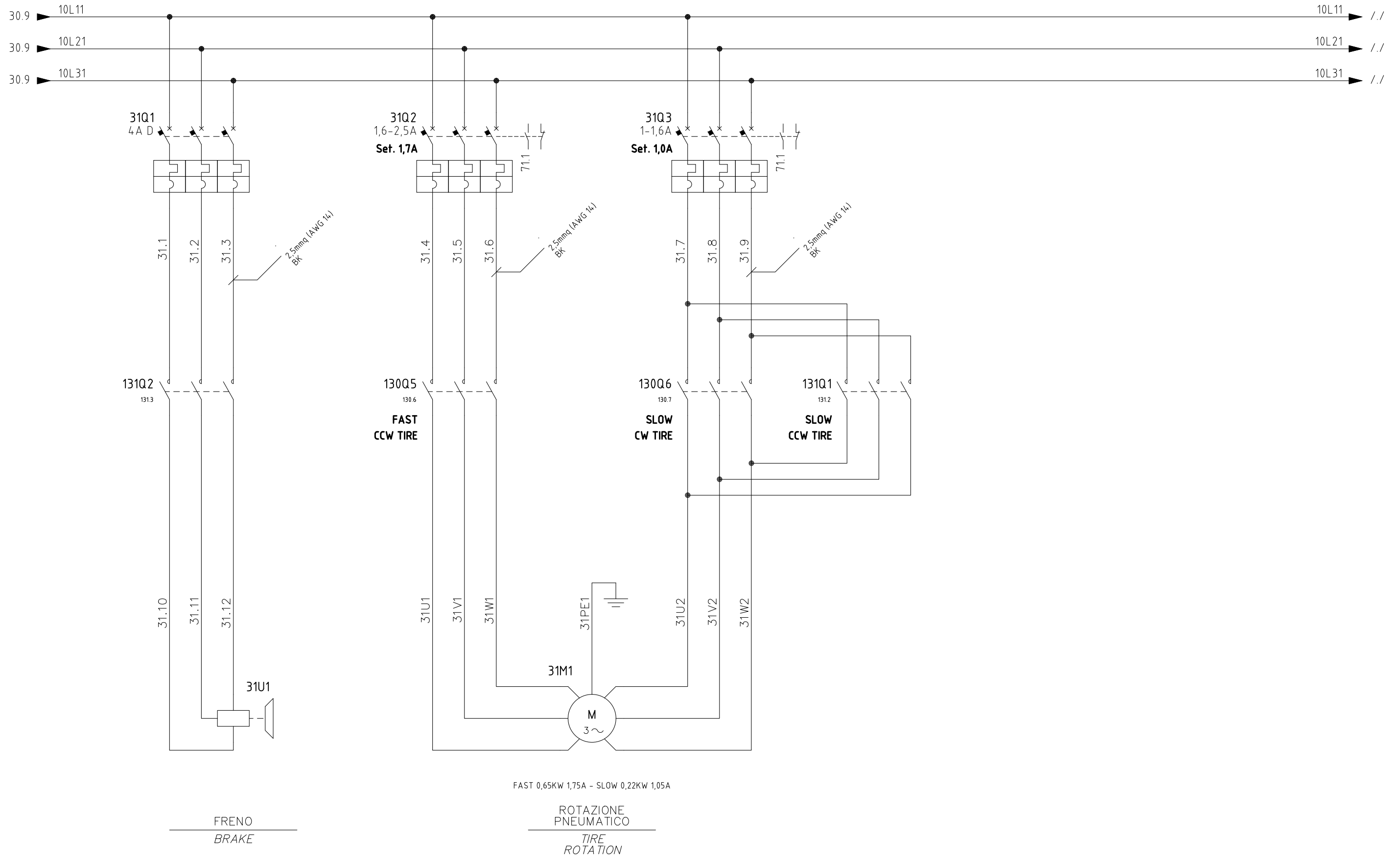

REV.	MODIFY	DATE	SIGN

Drawn	MATTEUZZI	Job	MEC 5693.1
Verified	MATTEUZZI	File Name	5693_1
Customer	MATTEUZZI	Date	16/07/2020

Title	MOTORI PARTENZA DIRETTA DIRECT START MOTOR	SHEET	31
Plant	POWER AND AUXILIARY RAS 405 UL	NEXT	32

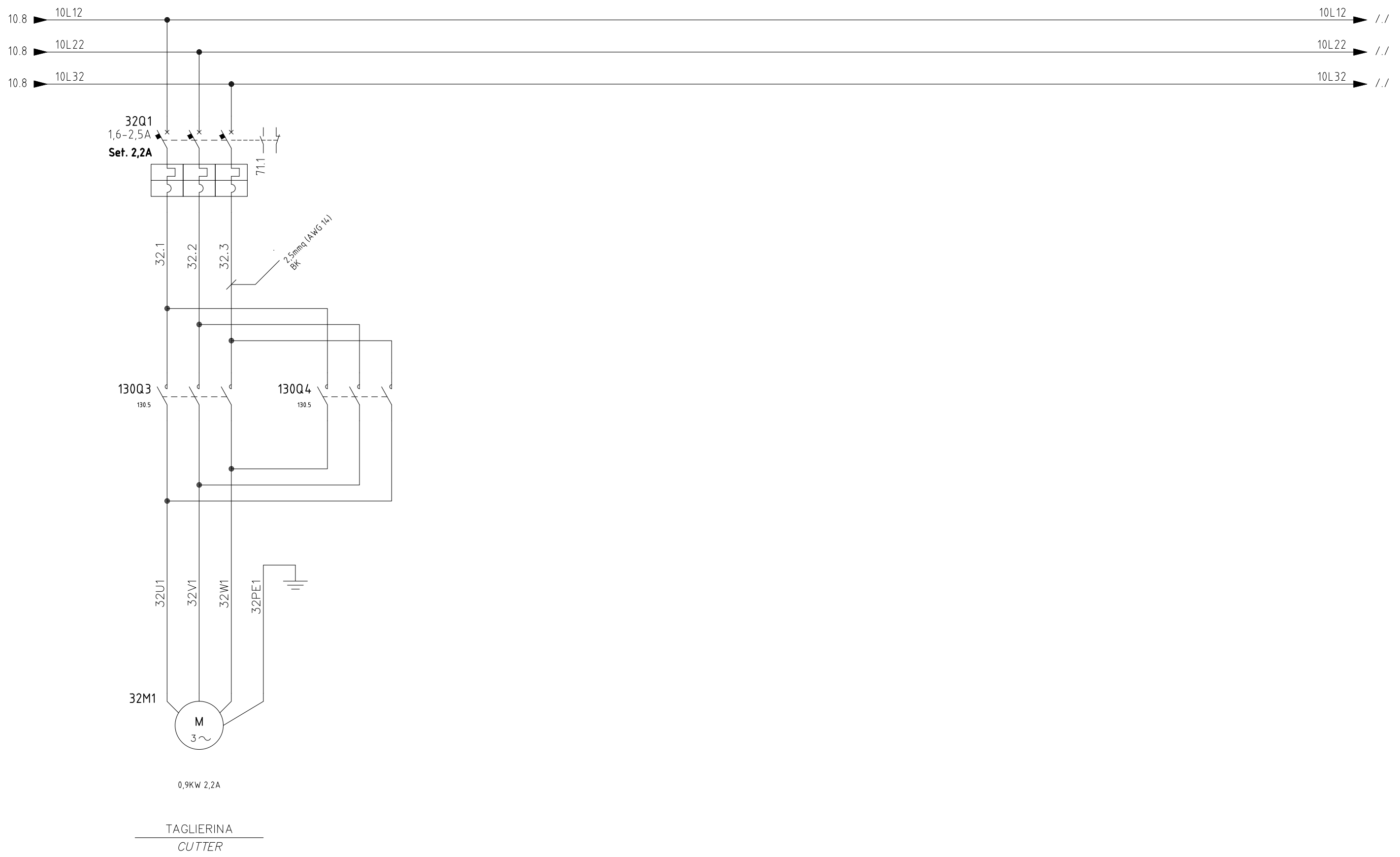

matteuzzi srl
 Calderara di Reno
 (BO) ITALY

REV.	MODIFY	DATE	SIGN

Drawn	MATTEUZZI	Job	MEC 5693.1
Verified	MATTEUZZI	File Name	5693_1
Customer	MATTEUZZI	Date	16/07/2020

Title	MOTORI PARTENZA DIRETTA DIRECT START MOTOR
Plant	POWER AND AUXILIARY RAS 405 UL

SHEET	32
NEXT	41

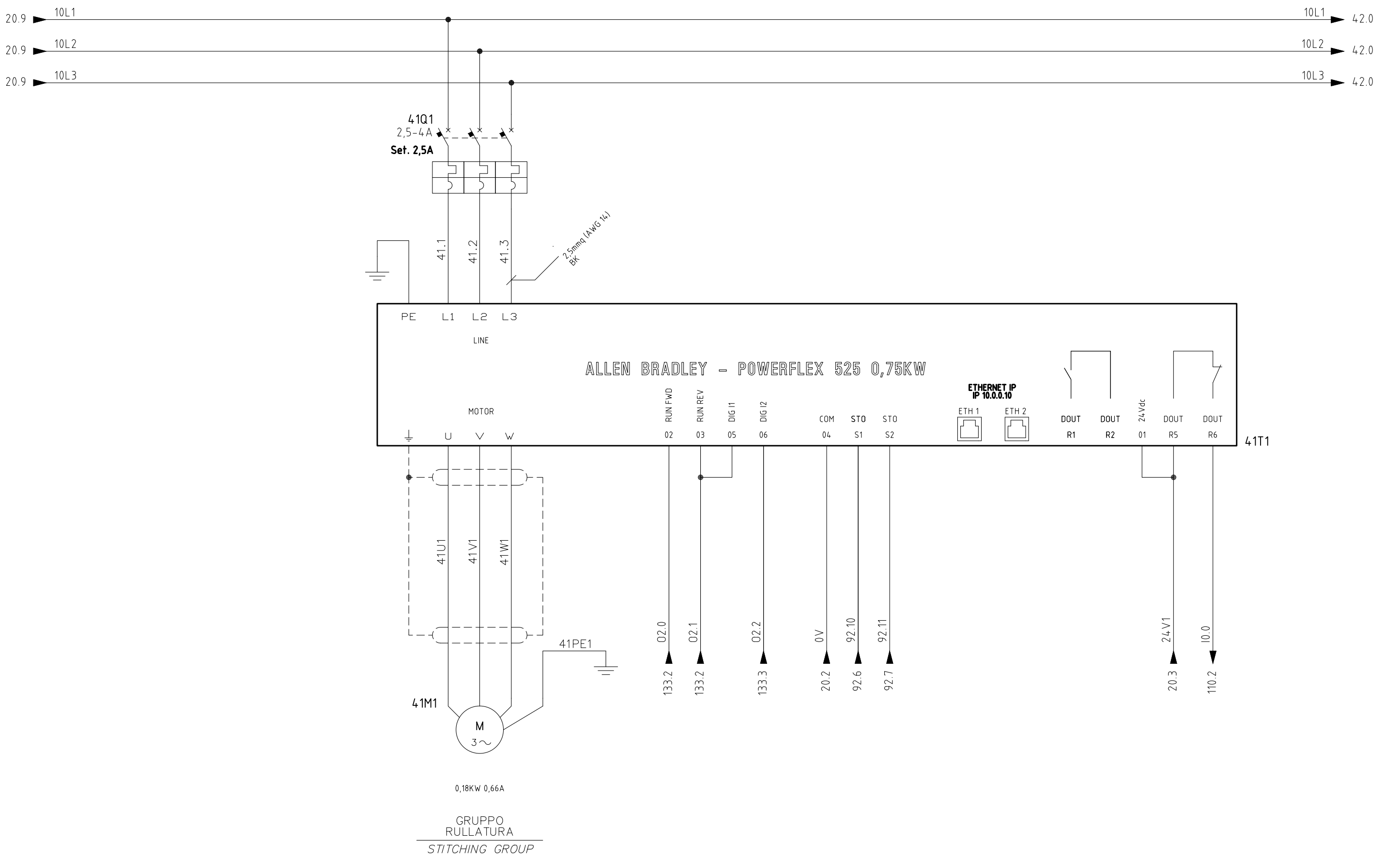

REV.	MODIFY	DATE	SIGN

Drawn	MATTEUZZI	Job	MEC 5693.1
Verified	MATTEUZZI	File Name	5693_1
Customer	MATTEUZZI	Date	16/07/2020

Title	INVERTER GRUPPO RULLATURA STITCHING GROUP INVERTER	SHEET	41
Plant	POWER AND AUXILIARY RAS 405 UL	NEXT	42

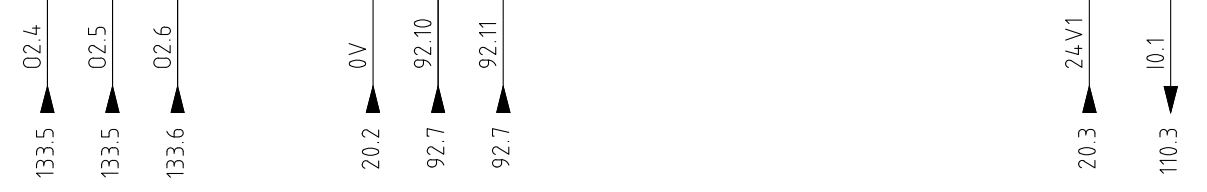
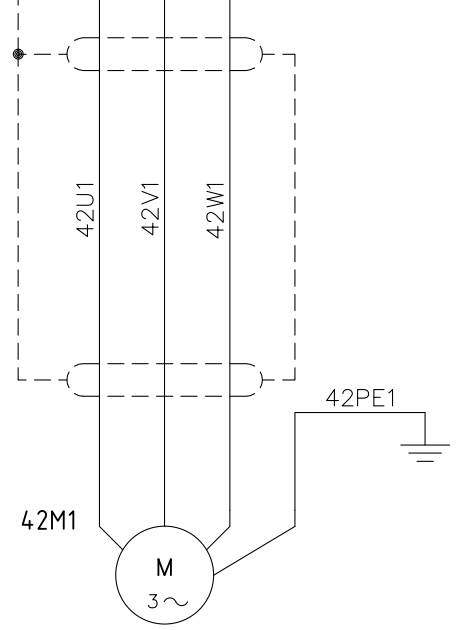
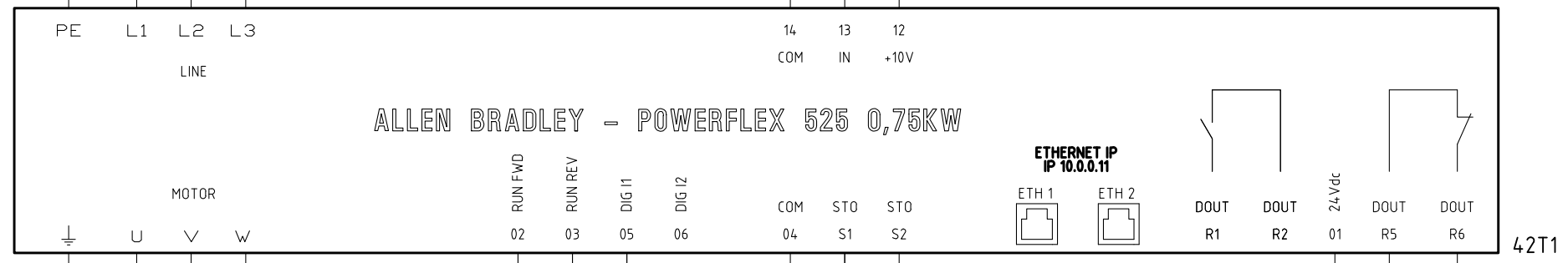
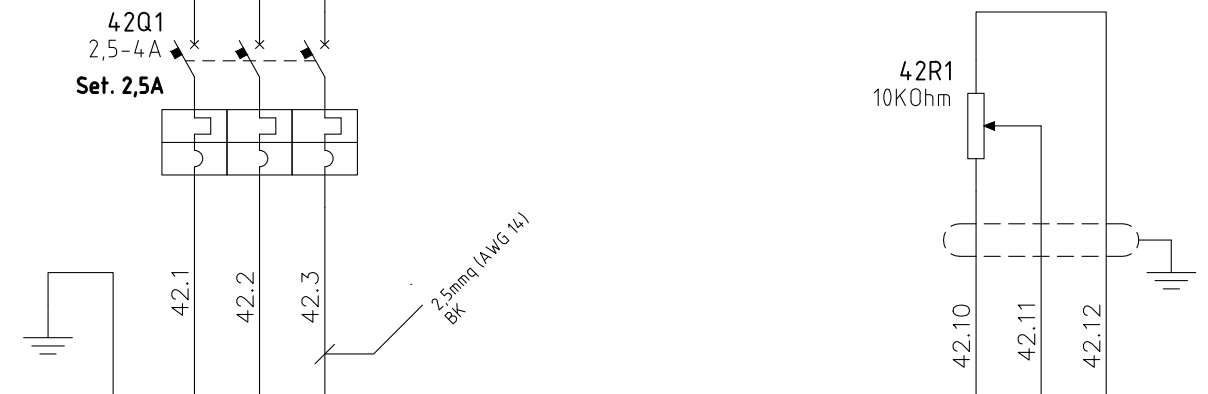
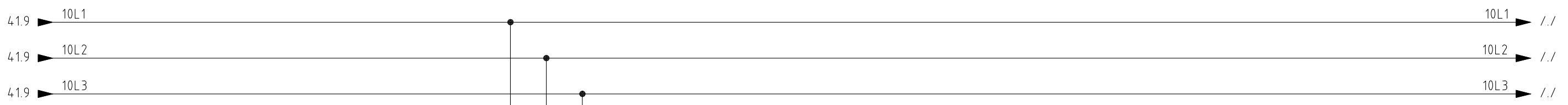

0,18KW 0,66A

POLY
POLY

REV.	MODIFY	DATE	SIGN

Drawn	MATTEUZZI	Job	MEC 5693.1
Verified	MATTEUZZI	File Name	5693_1
Customer	MATTEUZZI	Date	16/07/2020

Title	INVERTER POLY POLY INVERTER	SHEET	42
Plant	POWER AND AUXILIARY RAS 405 UL	NEXT	70

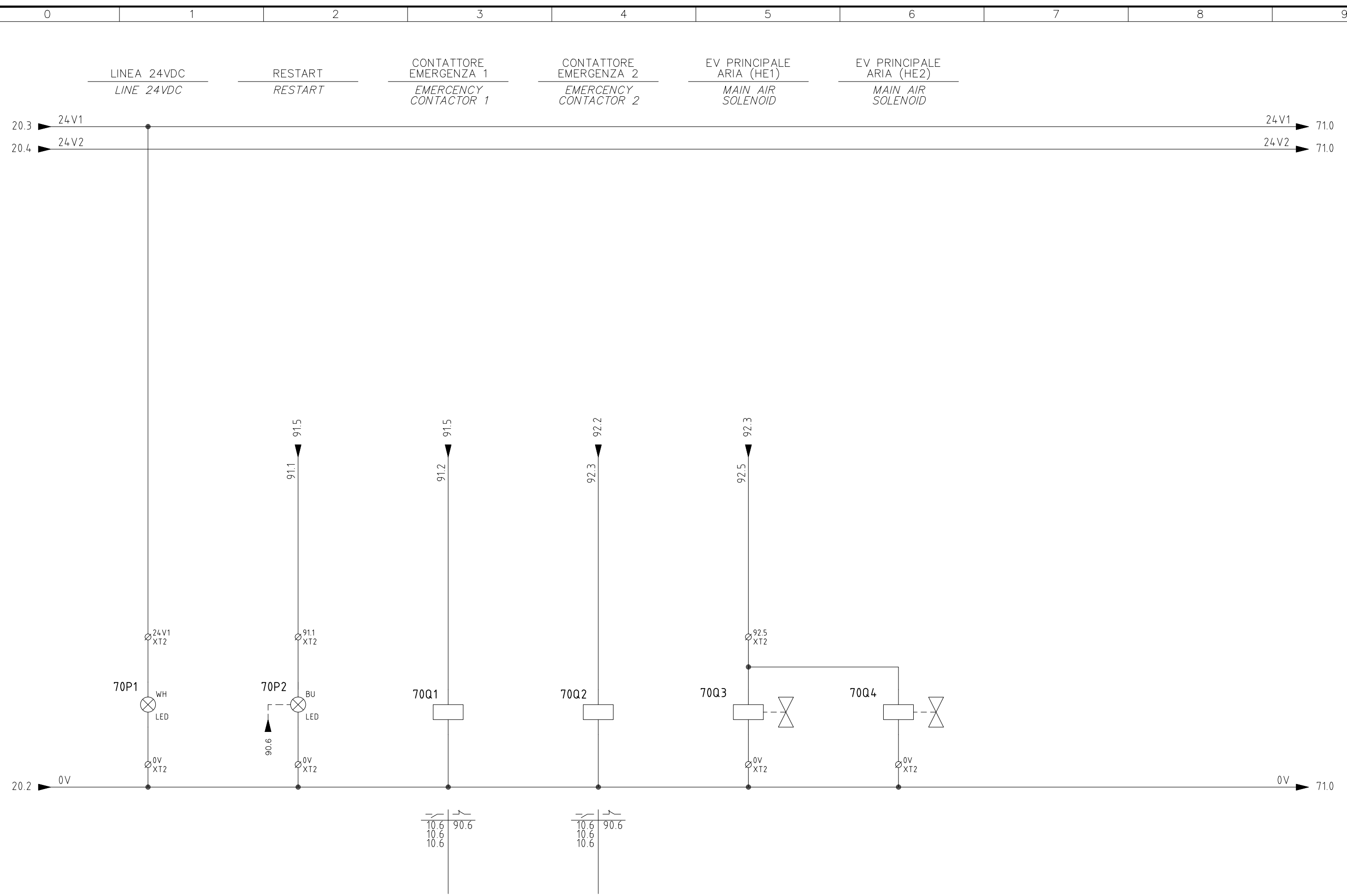

REV.	MODIFY	DATE	SIGN

Drawn	MATTEUZZI	Job	MEC 5693.1
Verified	MATTEUZZI	File Name	5693_1
Customer	MATTEUZZI	Date	16/07/2020

Title	AUSILIARI 24VDC AUXILIARY 24VDC	SHEET	70
Plant	POWER AND AUXILIARY RAS 405 UL	NEXT	71

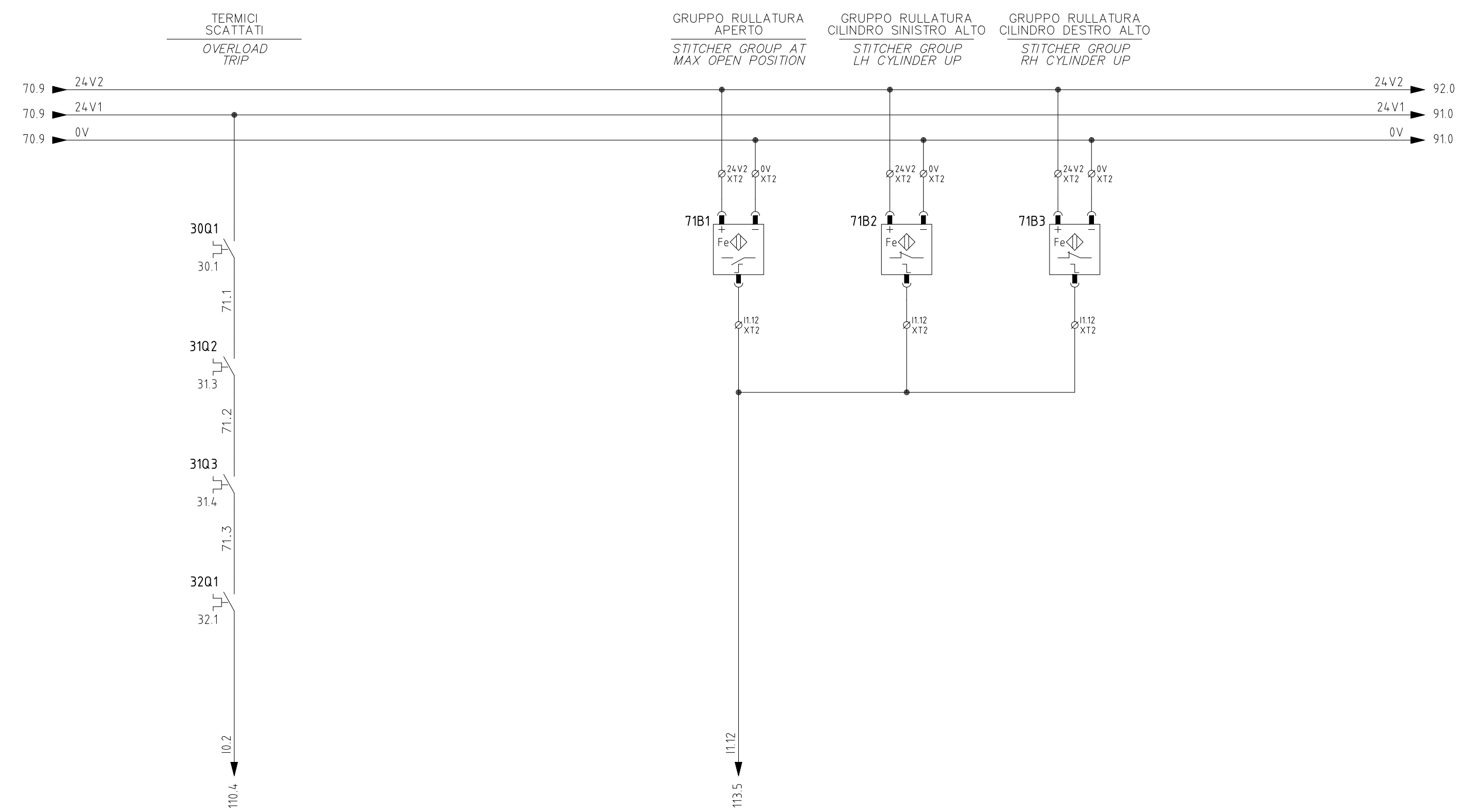

REV.	MODIFY	DATE	SIGN

Drawn	MATTEUZZI	Job	MEC 5693.1
Verified	MATTEUZZI	File Name	5693_1
Customer	MATTEUZZI	Date	16/07/2020

Title	AUSILIARI 24VDC AUXILIARY 24VDC	SHEET	71
Plant	POWER AND AUXILIARY RAS 405 UL	NEXT	90

20.5 \blacktriangleright 24V4 24V4 \blacktriangleright 110.0

FUNGO EMERGENZA
PULPITO
*E-STOP PUSHBUTTON
ON CONTROL PANEL*

FUNGO EMERGENZA
RULLATURA
*E-STOP PUSHBUTTON
STITCHING ZONE*

EMERGENZA
RISERVA
*SPARE
EMERGENCY*

RESET
EMERGENZA
*RESET
EMERGENCY*

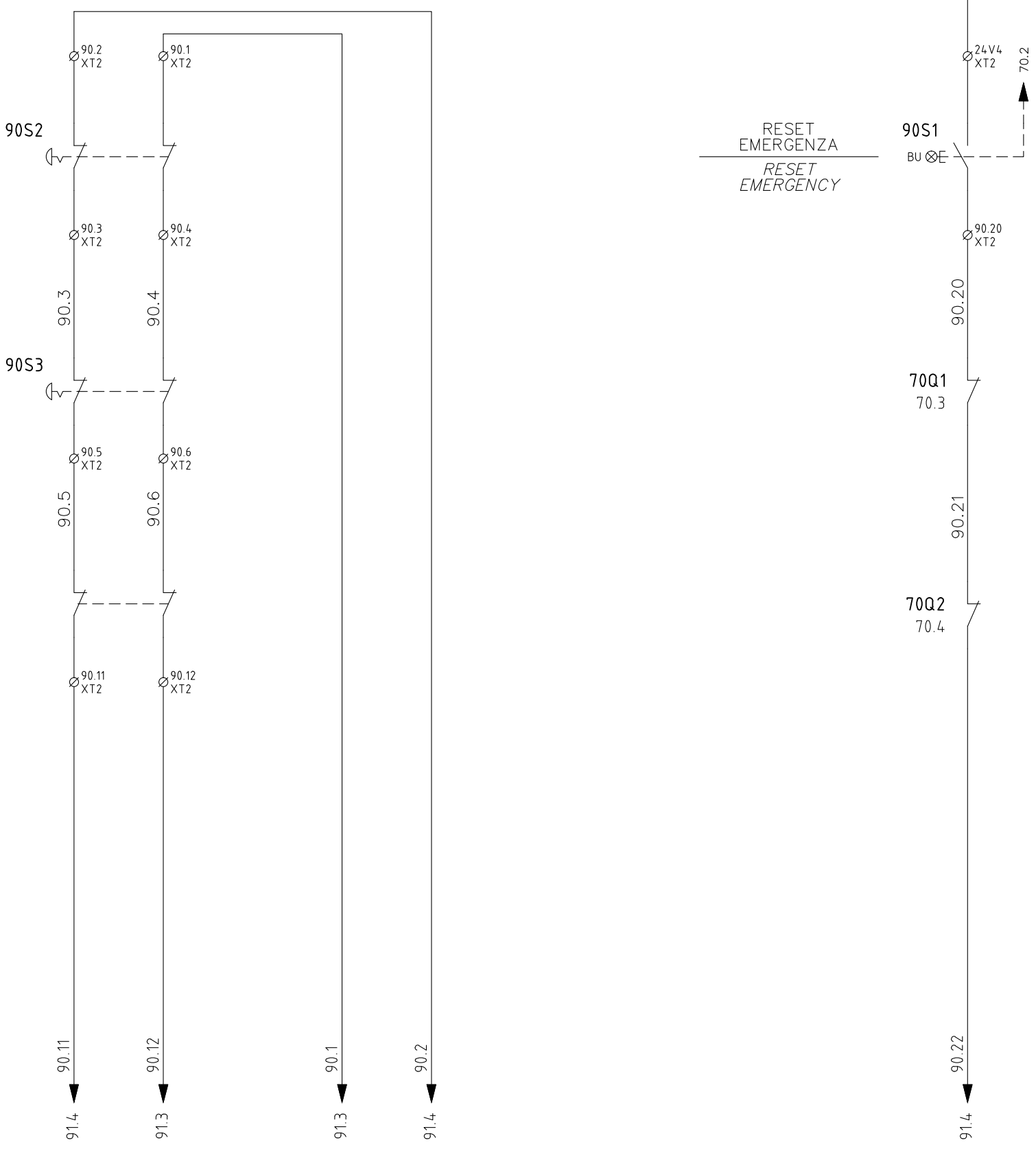

REV.	MODIFY	DATE	SIGN

Drawn	MATTEUZZI	Job	MEC 5693.1
Verified	MATTEUZZI	File Name	5693_1
Customer	MATTEUZZI	Date	16/07/2020

Title	CATENA EMERGENZA EMERGENCY LINE	SHEET	90
Plant	POWER AND AUXILIARY RAS 405 UL	NEXT	91

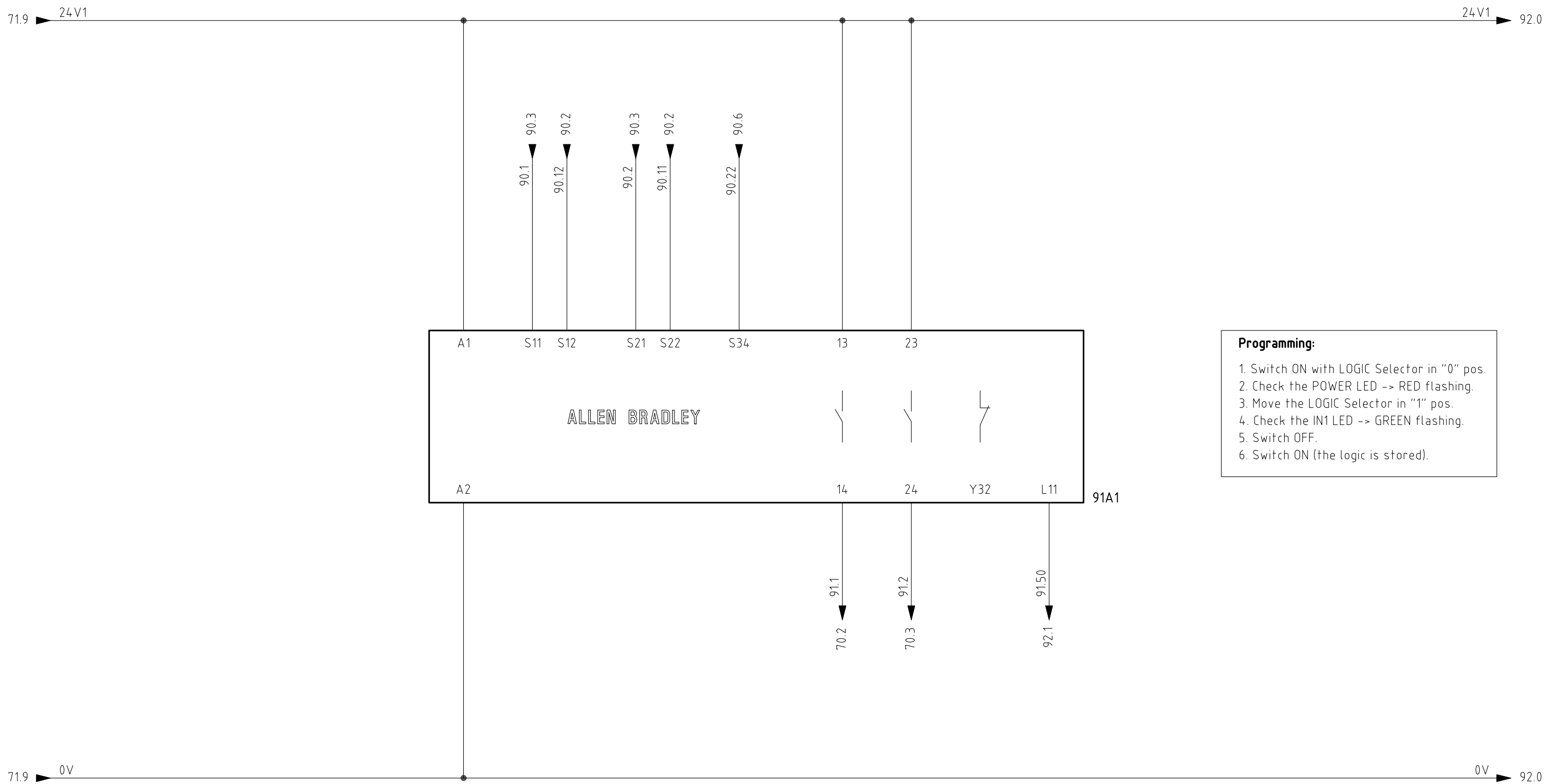

Programming:

1. Switch ON with LOGIC Selector in "0" pos.
2. Check the POWER LED -> RED flashing.
3. Move the LOGIC Selector in "1" pos.
4. Check the IN1 LED -> GREEN flashing.
5. Switch OFF.
6. Switch ON (the logic is stored).

REV.	MODIFY	DATE	SIGN

Drawn	MATTEUZZI	Job	MEC 5693.1
Verified	MATTEUZZI	File Name	5693_1
Customer	MATTEUZZI	Date	16/07/2020

Title	EMERGENZA	SHEET	91
	EMERGENCY	NEXT	92
Plant	POWER AND AUXILIARY RAS 405 UL		

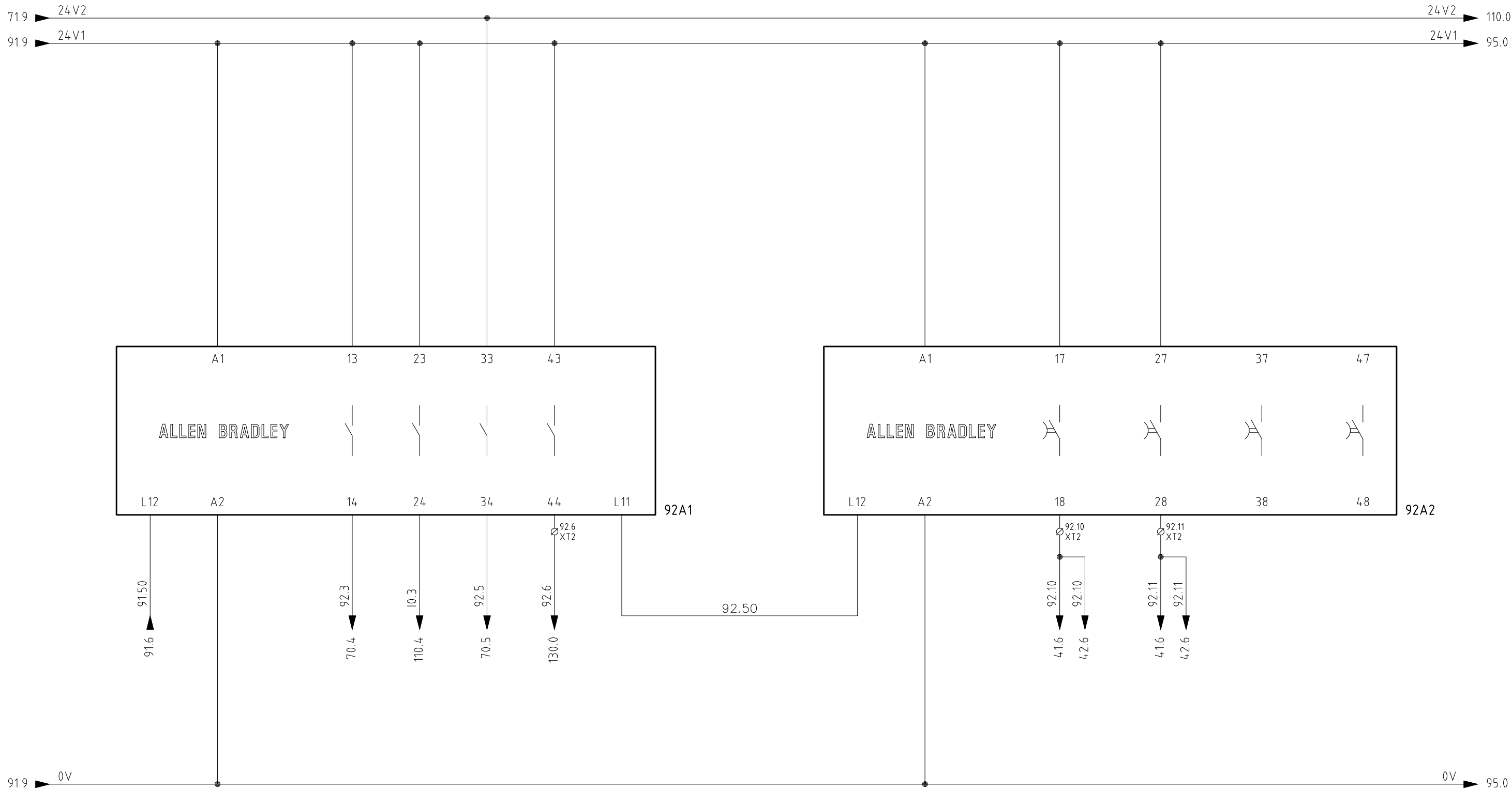

matteuzzi srl
 Calderara di Reno
 (BO) ITALY

REV.	MODIFY	DATE	SIGN

Drawn	MATTEUZZI
Verified	MATTEUZZI
Customer	MATTEUZZI

Job	MEC 5693.1
File Name	5693_1
Date	16/07/2020

Title	EMERGENZA EMERGENCY
Plant	POWER AND AUXILIARY RAS 405 UL

SHEET
92
NEXT
95

ABILITAZIONE
MOTORE LAMA
CUTTER MOTOR
ENABLE

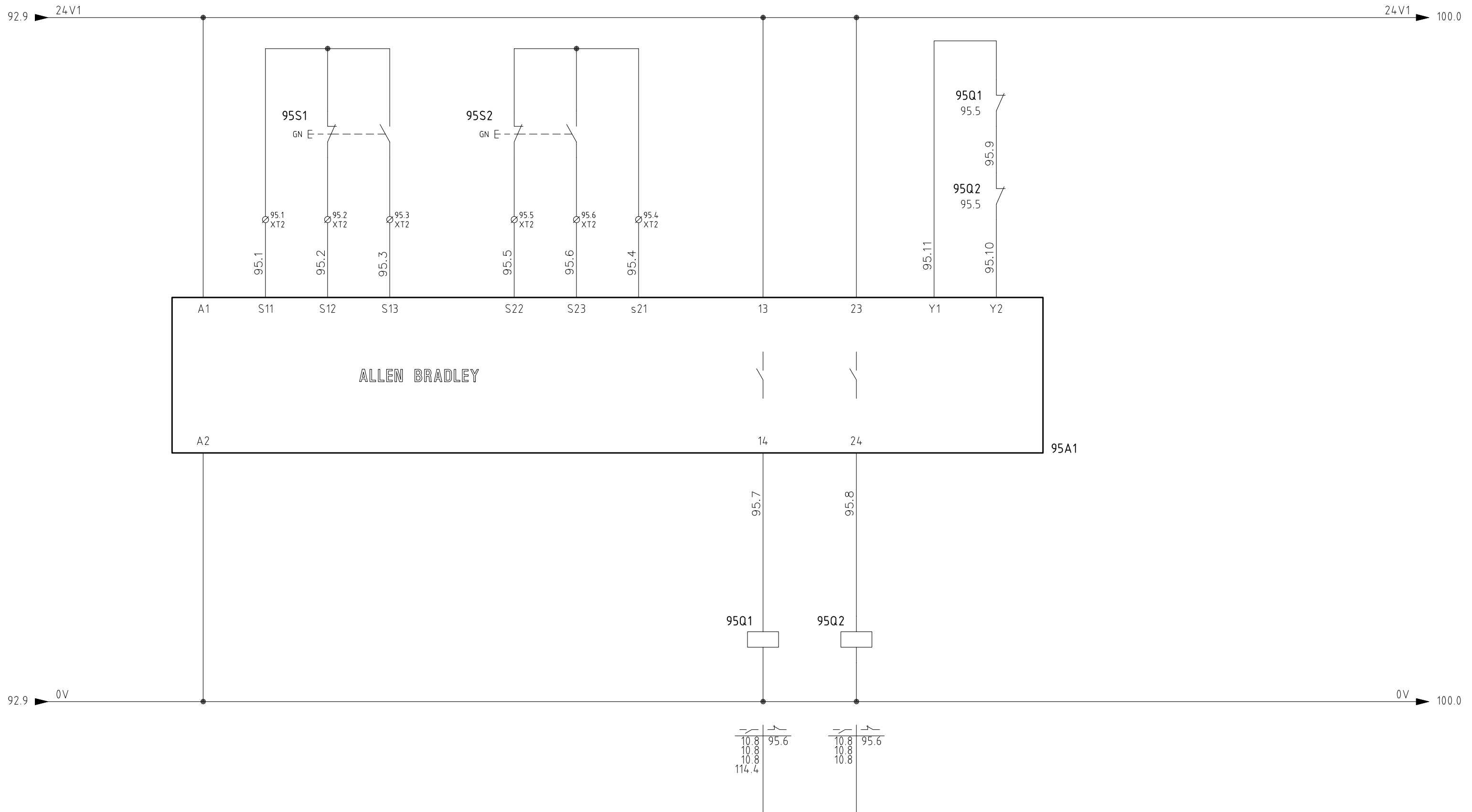

matteuzzi srl
Calderara di Reno
(BO) ITALY

REV.	MODIFY	DATE	SIGN

Drawn	MATTEUZZI	Job	MEC 5693.1
Verified	MATTEUZZI	File Name	5693_1
Customer	MATTEUZZI	Date	16/07/2020

Title	SICUREZZA COMANDO A DUE MANI BI-MANUAL COMMAND SAFETY DEVICE
Plant	POWER AND AUXILIARY RAS 405 UL

SHEET
95
NEXT
100

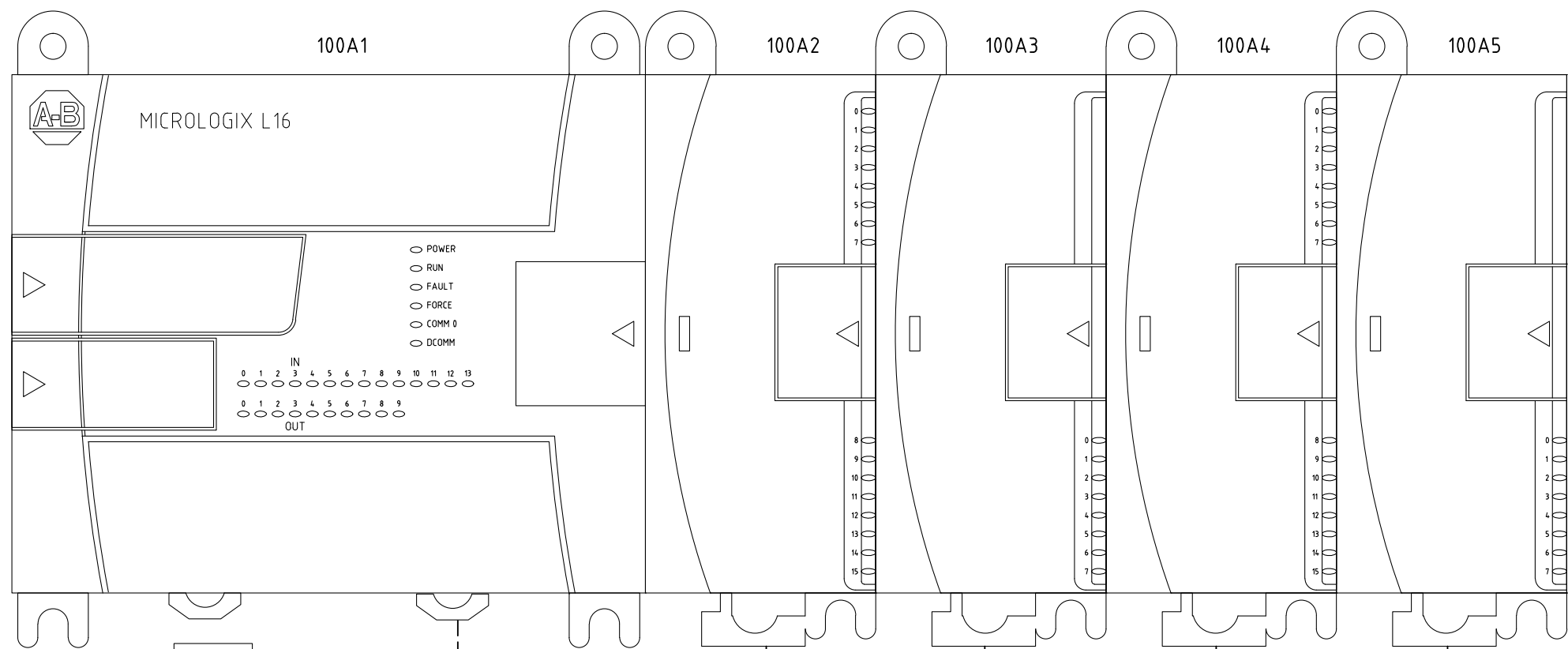

- POWER
- RUN
- FAULT
- FORCE
- COMM 0
- DCOMM

IN 0 1 2 3 4 5 6 7 8 9 10 11 12 13
 OUT 0 1 2 3 4 5 6 7 8 9

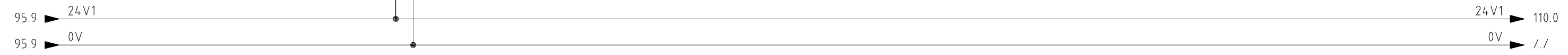
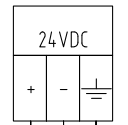

REV.	MODIFY	DATE	SIGN

Drawn	MATTEUZZI	Job	MEC 5693.1
Verified	MATTEUZZI	File Name	5693_1
Customer	MATTEUZZI	Date	16/07/2020

Title	RACK PLC	SHEET	100
	PLC RACK		
Plant	PLC RAS 405 UL	NEXT	110

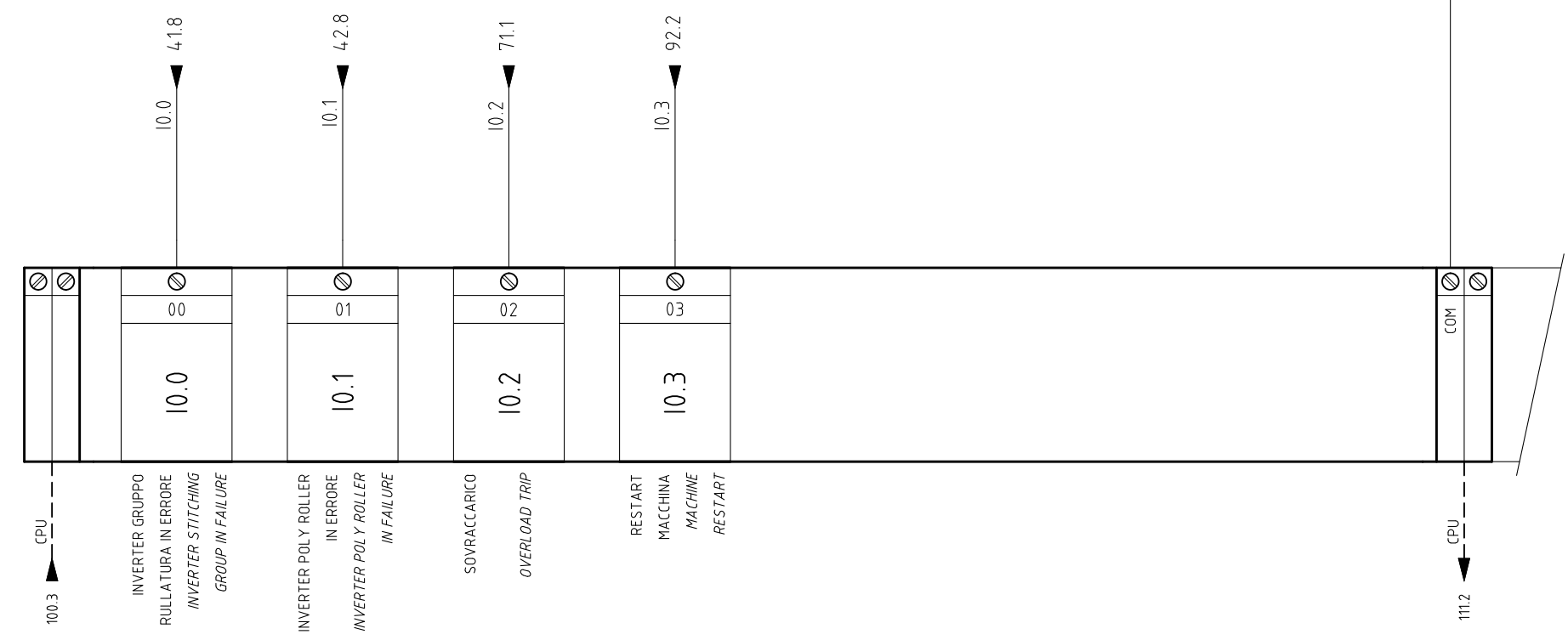
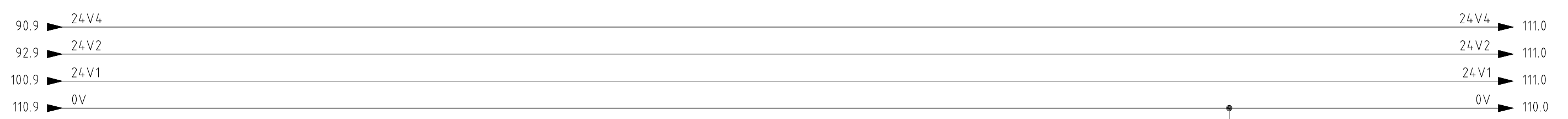

REV.	MODIFY	DATE	SIGN

Drawn	MATTEUZZI	Job	MEC 5693.1
Verified	MATTEUZZI	File Name	5693_1
Customer	MATTEUZZI	Date	16/07/2020

Title	INPUT DIGITALI DIGITAL INPUTS	SHEET	110
Plant	PLC RAS 405 UL	NEXT	111

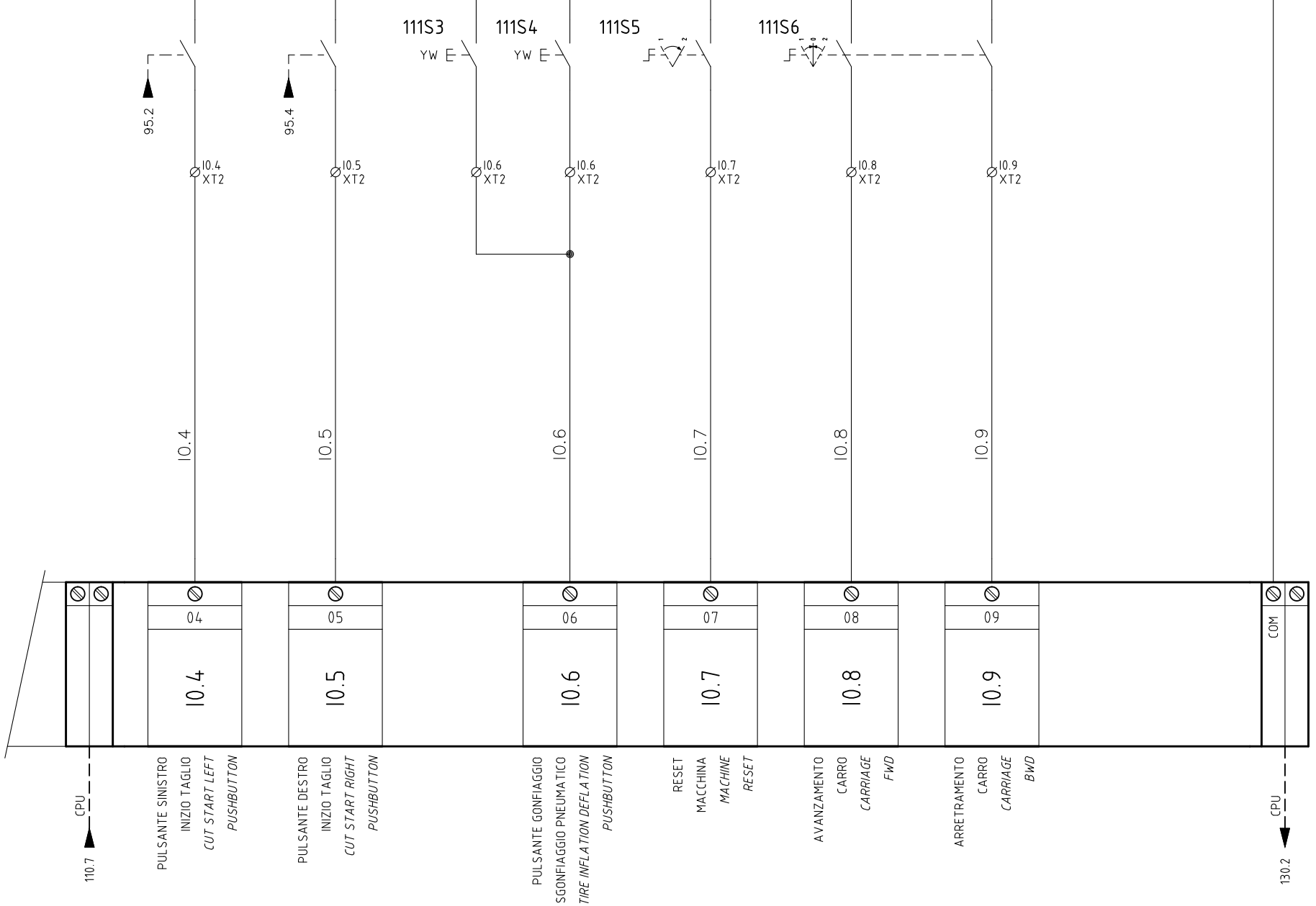
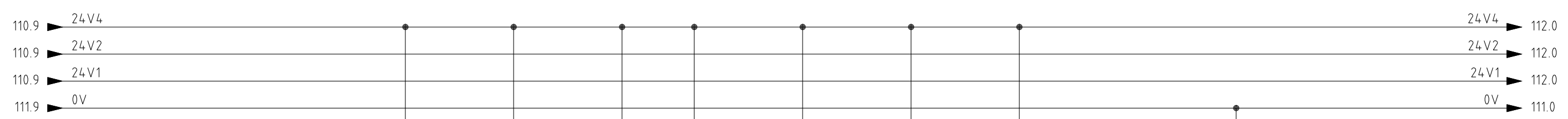

04	05	06	07	08	09	COM
10.4	10.5	10.6	10.7	10.8	10.9	

110.7 CPU
 PULSANTE SINISTRO INIZIO TAGLIO CUT START LEFT PUSHBUTTON
 PULSANTE DESTRO INIZIO TAGLIO CUT START RIGHT PUSHBUTTON
 PULSANTE GONFIAGGIO SGONFIAGGIO PNEUMATICO TIRE INFLATION DEFLATION PUSHBUTTON
 RESET MACCHINA MACHINE RESET
 AVANZAMENTO CARRO CARRIAGE FWD
 ARRETRAMENTO CARRO CARRIAGE BWD
 130.2 CPU

REV.	MODIFY	DATE	SIGN

Drawn	MATTEUZZI	Job	MEC 5693.1
Verified	MATTEUZZI	File Name	5693_1
Customer	MATTEUZZI	Date	16/07/2020

Title	INPUT DIGITALI DIGITAL INPUTS	SHEET	111
Plant	PLC RAS 405 UL	NEXT	112

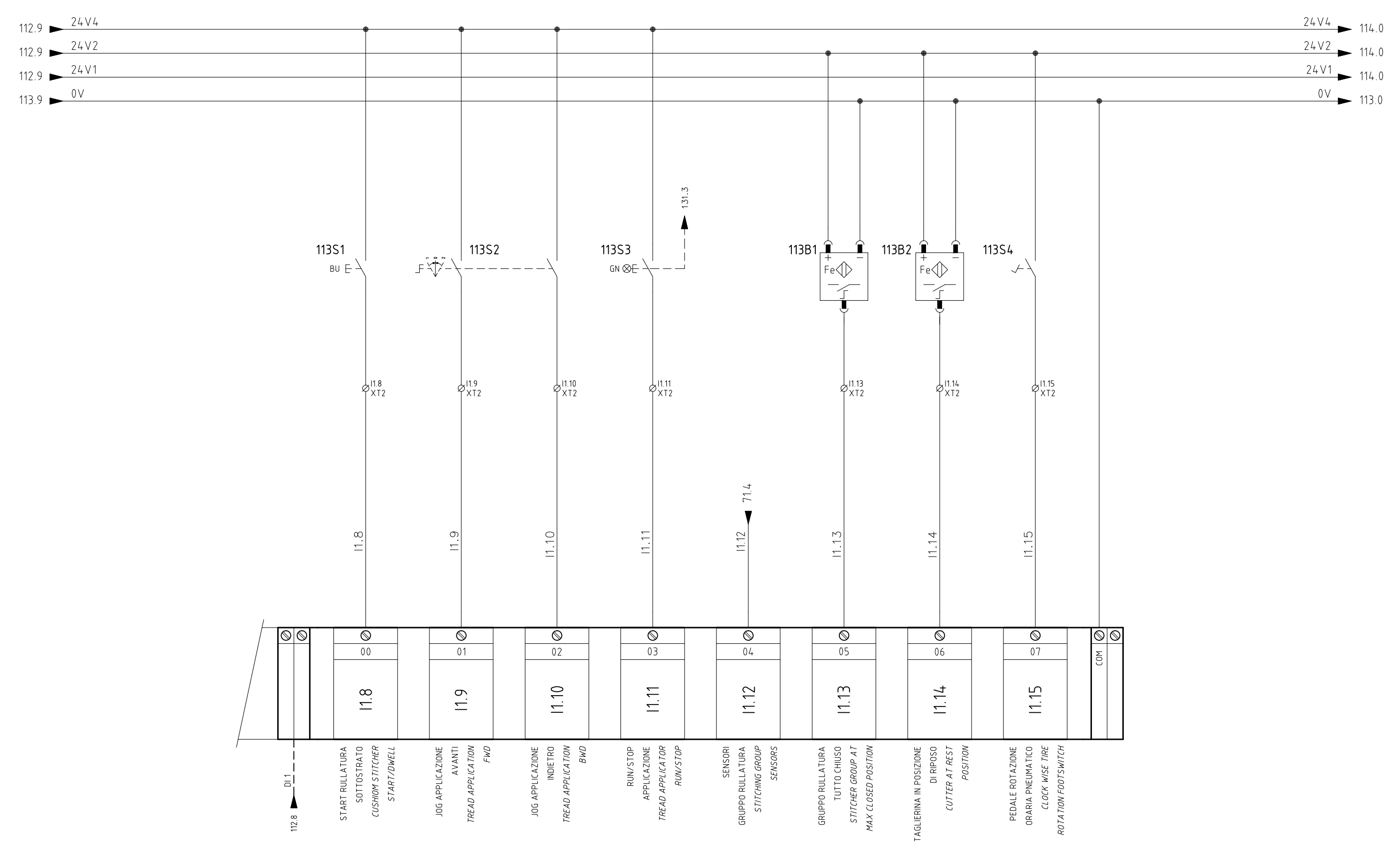

REV.	MODIFY	DATE	SIGN

Drawn	MATTEUZZI	Job	MEC 5693.1
Verified	MATTEUZZI	File Name	5693_1
Customer	MATTEUZZI	Date	16/07/2020

Title	INPUT DIGITALI DIGITAL INPUTS	SHEET	113
Plant	PLC RAS 405 UL	NEXT	114

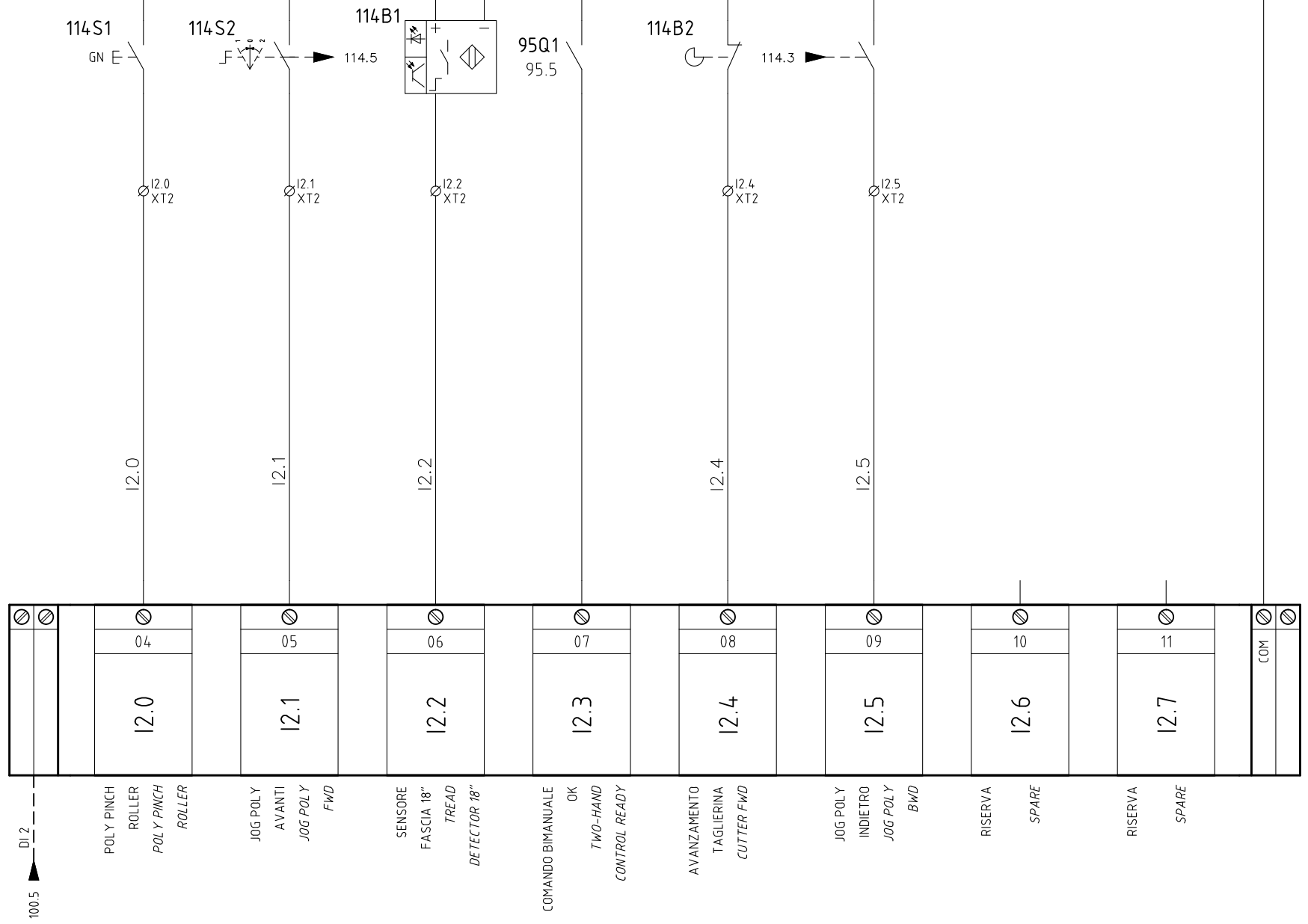
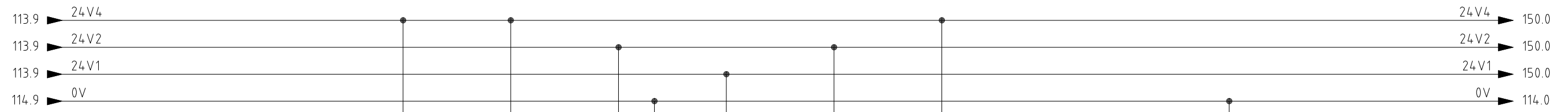

REV.	MODIFY	DATE	SIGN

Drawn	MATTEUZZI	Job	MEC 5693.1
Verified	MATTEUZZI	File Name	5693_1
Customer	MATTEUZZI	Date	16/07/2020

Title	INPUT DIGITALI	SHEET
	DIGITAL INPUTS	
Plant	PLC RAS 405 UL	NEXT
		130

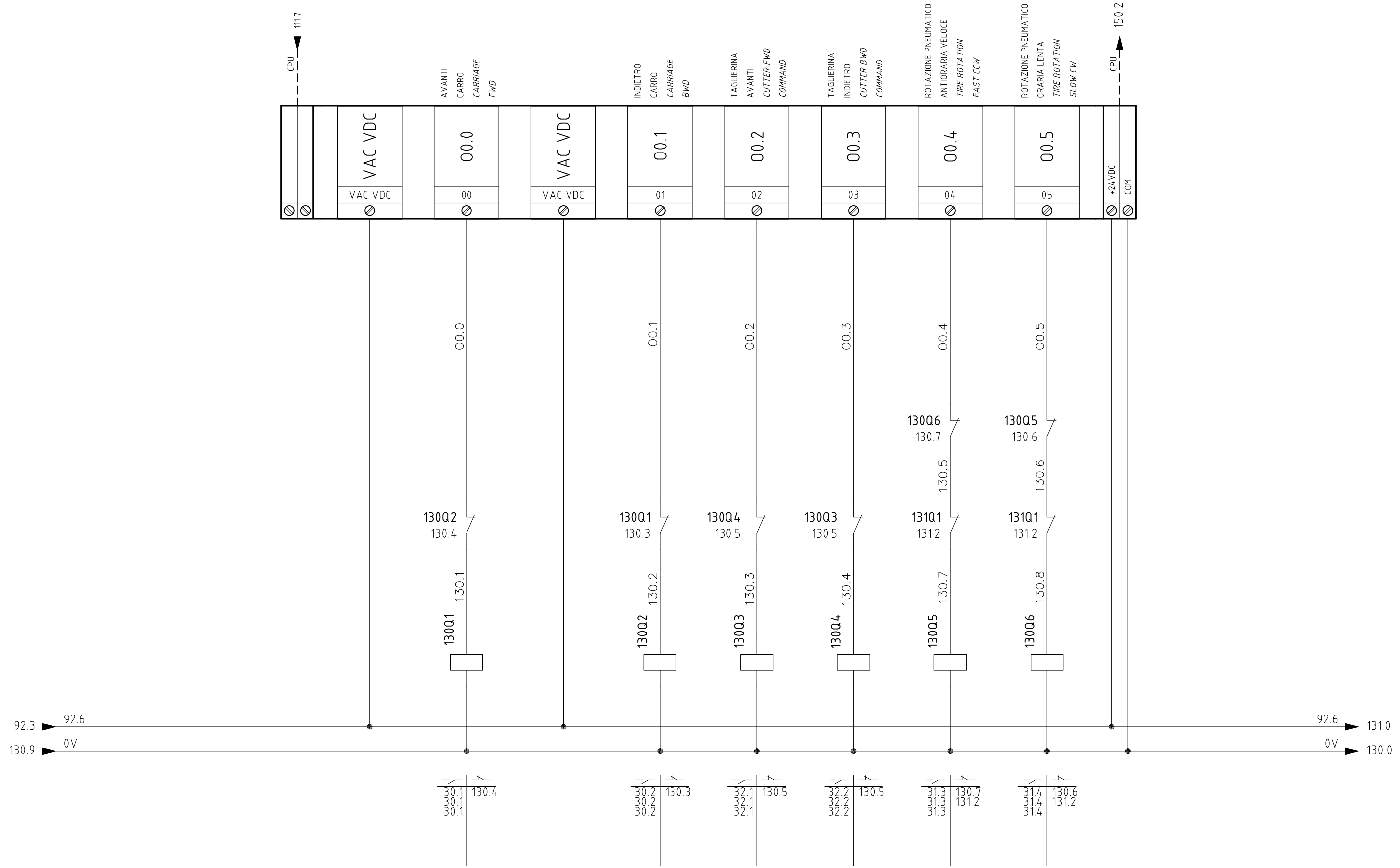

REV.	MODIFY	DATE	SIGN

Drawn	MATTEUZZI	Job	MEC 5693.1
Verified	MATTEUZZI	File Name	5693_1
Customer	MATTEUZZI	Date	16/07/2020

Title	OUTPUT DIGITALI DIGITAL OUTPUTS	SHEET	130
Plant	PLC RAS 405 UL	NEXT	131

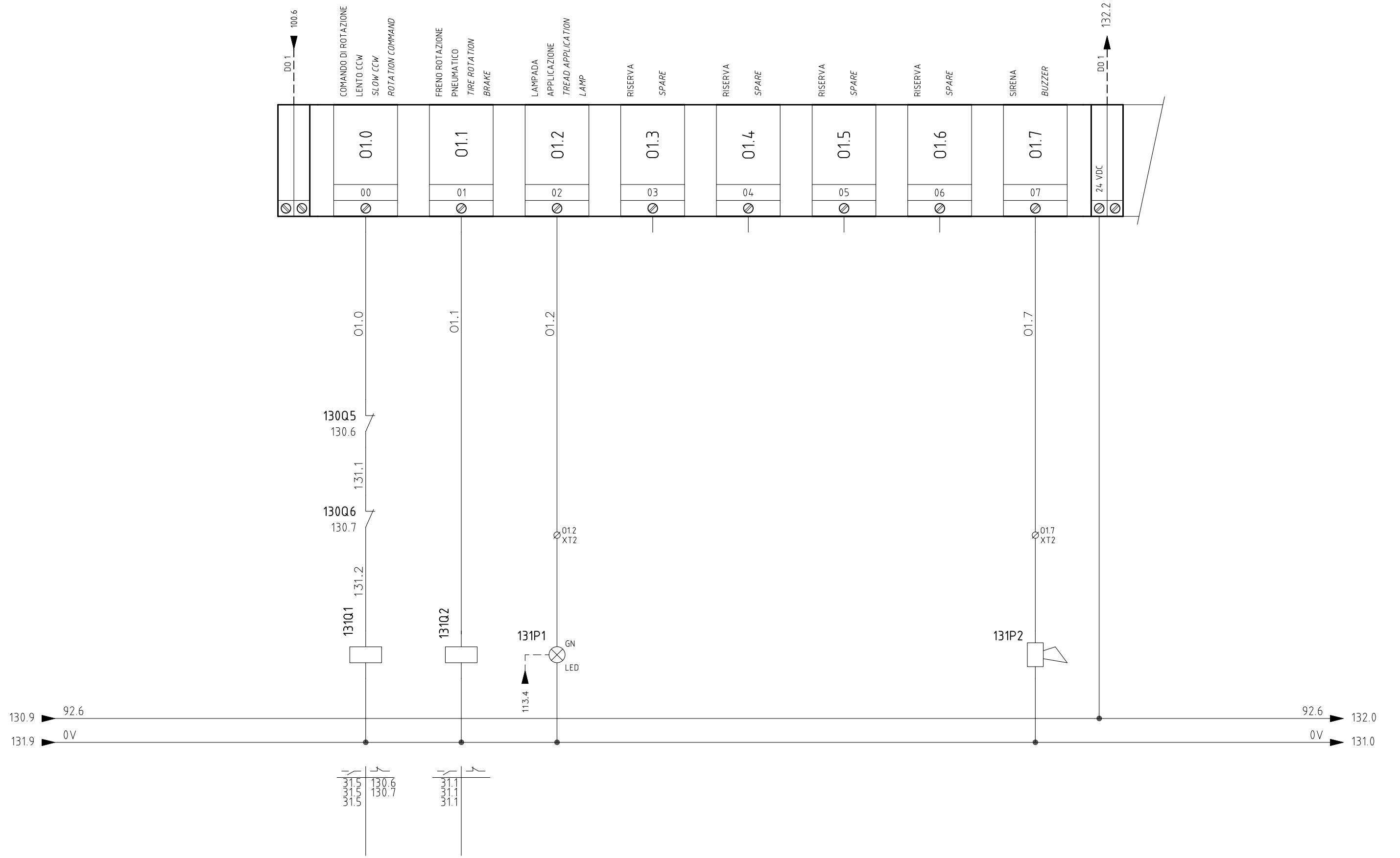

REV.	MODIFY	DATE	SIGN

Drawn	MATTEUZZI	Job	MEC 5693.1
Verified	MATTEUZZI	File Name	5693_1
Customer	MATTEUZZI	Date	16/07/2020

Title	OUTPUT DIGITALI DIGITAL OUTPUTS	SHEET	131
Plant	PLC RAS 405 UL	NEXT	132

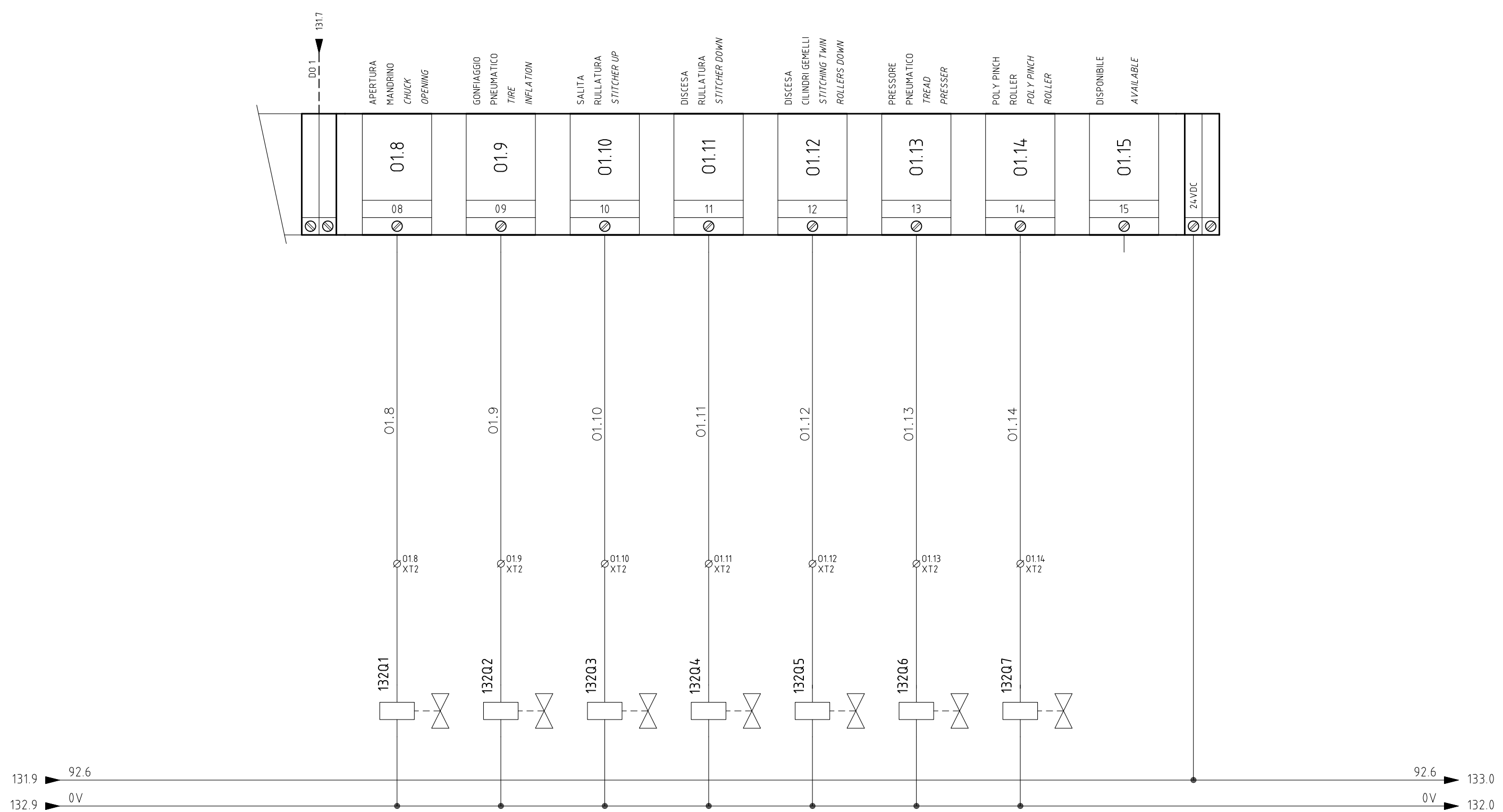

matteuzzi srl
 Calderara di Reno
 (BO) ITALY

REV.	MODIFY	DATE	SIGN

Drawn	MATTEUZZI
Verified	MATTEUZZI
Customer	MATTEUZZI

Job	MEC 5693.1
File Name	5693_1
Date	16/07/2020

Title	OUTPUT DIGITALI DIGITAL OUTPUTS
Plant	PLC RAS 405 UL

SHEET
132
NEXT
133

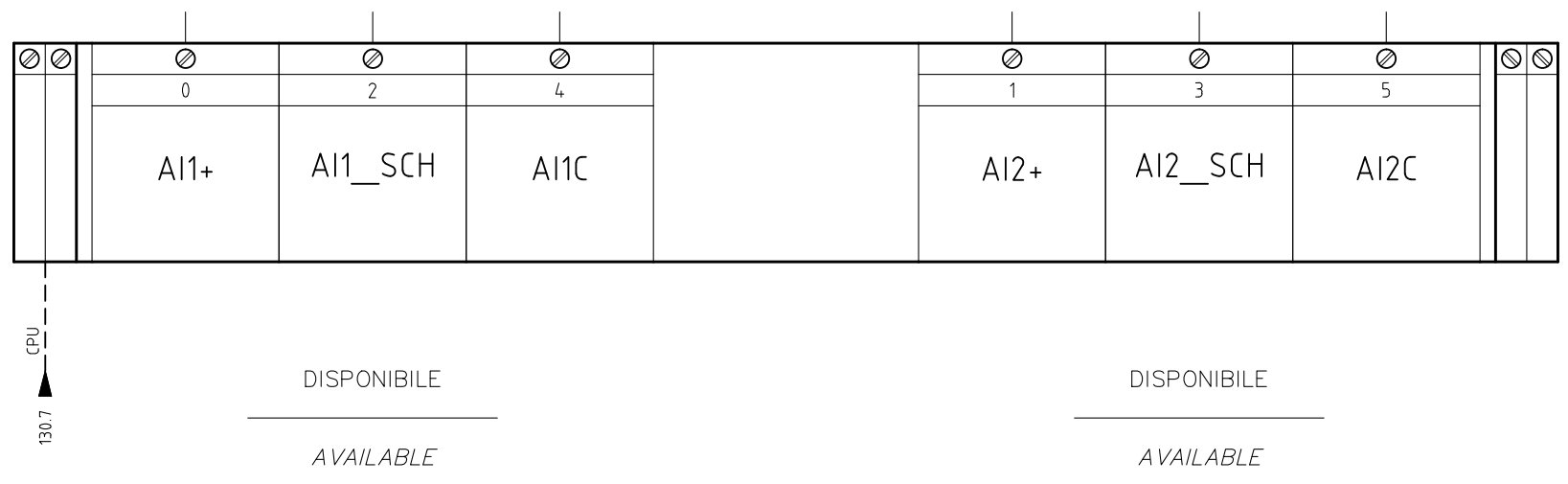

REV.	MODIFY	DATE	SIGN

Drawn	MATTEUZZI	Job	MEC 5693.1
Verified	MATTEUZZI	File Name	5693_1
Customer	MATTEUZZI	Date	16/07/2020

Title	INPUT ANALOGICI ANALOG INPUTS	SHEET	150
Plant	PLC RAS 405 UL	NEXT	800

=QG - XT0
 Morsettiera / Terminals XT0
 PE1  PE1



REV.	MODIFY	DATE	SIGN

Drawn	MATTEUZZI	Job	MEC 5693.1
Verified	MATTEUZZI	File Name	5693_1
Customer	MATTEUZZI	Date	16/07/2020

Title	MORSETTIERE XT0 E XT1 TERMINALS XT0 E XT1	SHEET 800
Plant	TERMINALS AND LAYOUT RAS 405 UL	

=QG - XT2
 Morsettiera / Terminals XT2

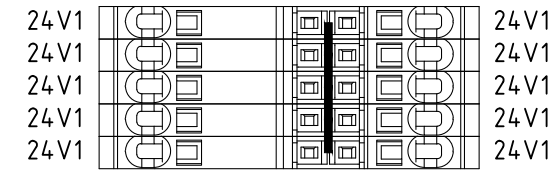
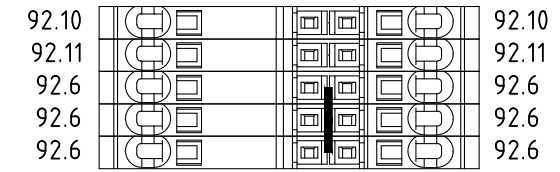
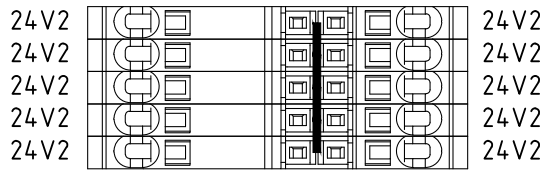
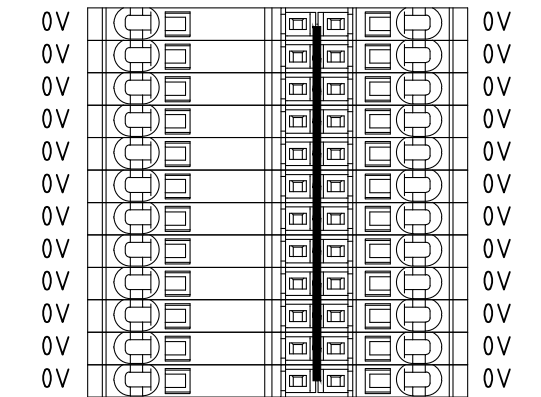
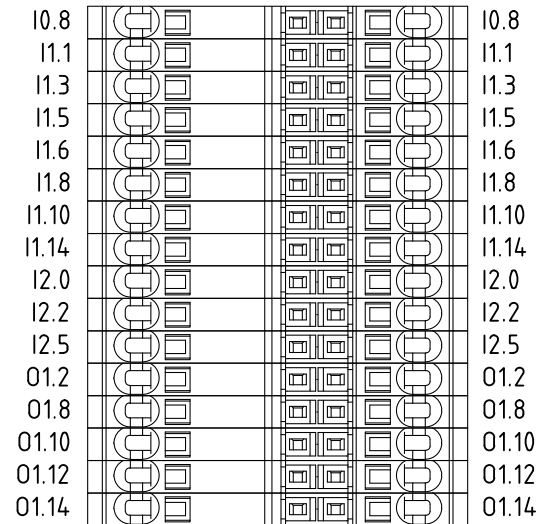
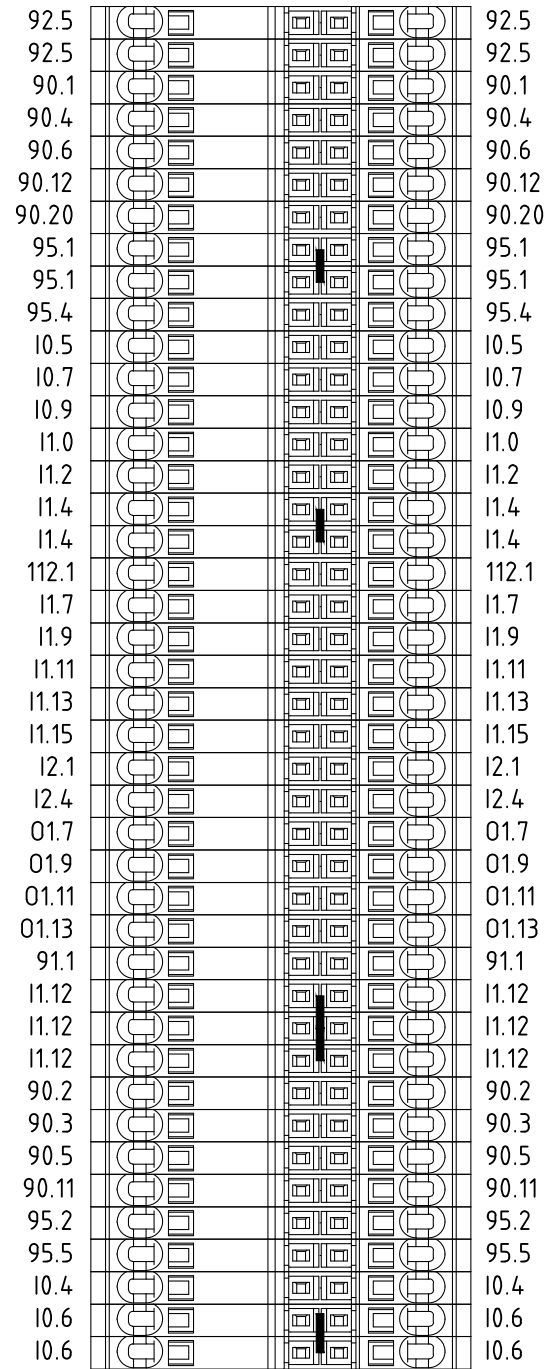

REV.	MODIFY	DATE	SIGN

Drawn	MATTEUZZI	Job	MEC 5693.1
Verified	MATTEUZZI	File Name	5693_1
Customer	MATTEUZZI	Date	16/07/2020

Title	MORSETTIERA XT2 TERMINALS XT2	SHEET	801
Plant	TERMINALS AND LAYOUT RAS 405 UL	NEXT	900

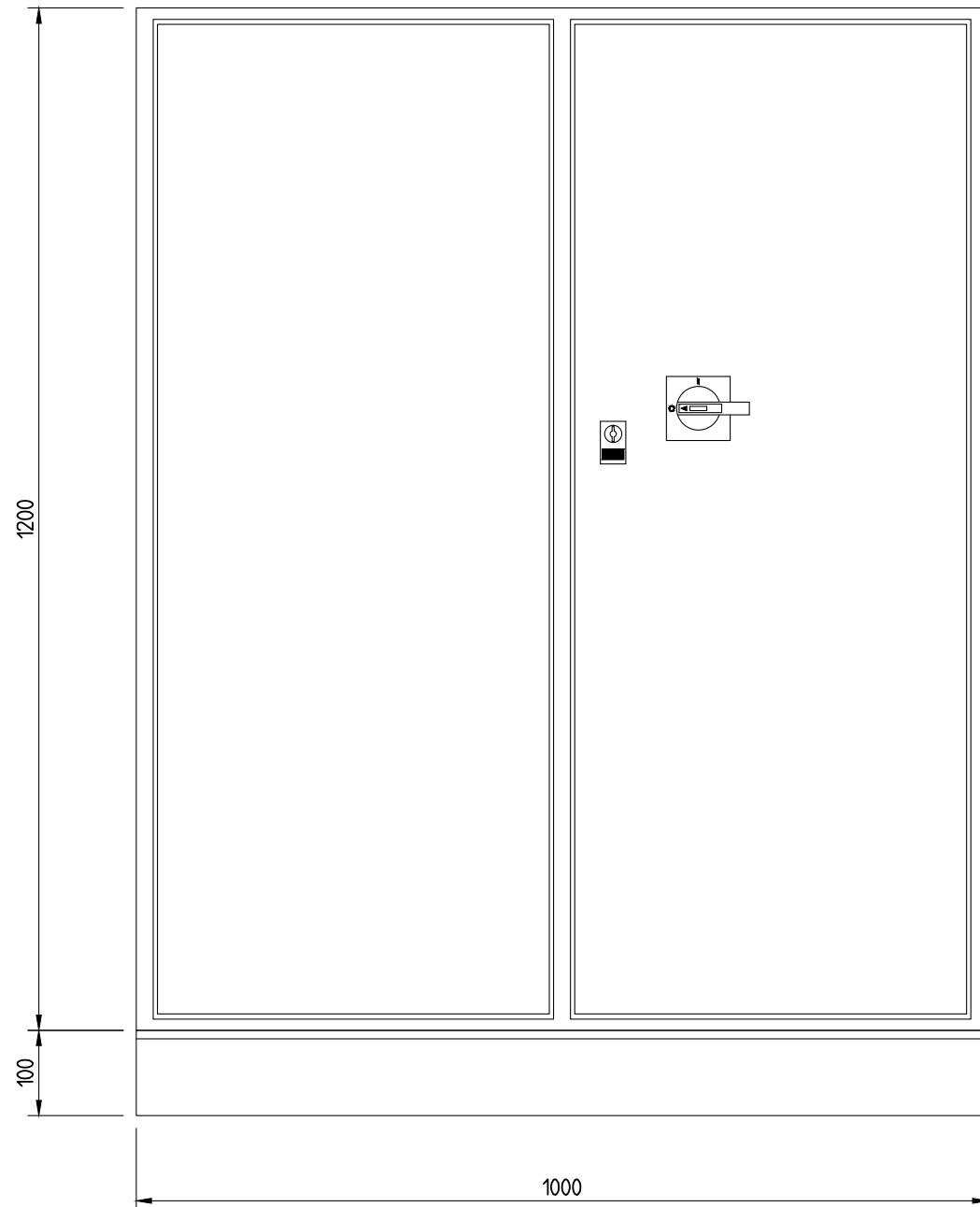

P=300

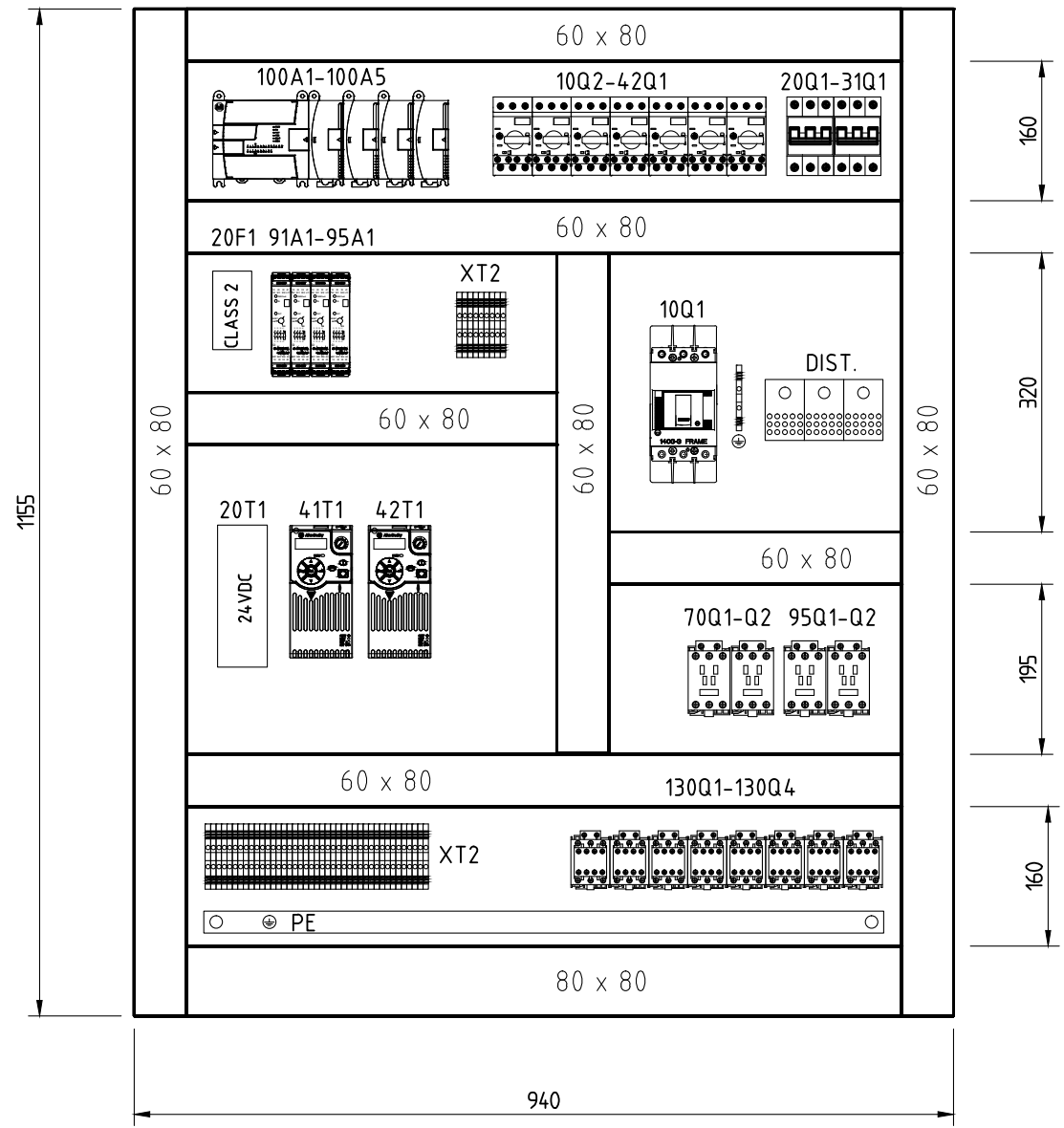

REV.	MODIFY	DATE	SIGN

Drawn	MATTEUZZI	Job	MEC 5693.1
Verified	MATTEUZZI	File Name	5693_1
Customer	MATTEUZZI	Date	16/07/2020

Title	LAYOUT QE RAS 405 UL RAS 405 UL LAYOUT QE	SHEET	900
Plant	TERMINALS AND LAYOUT RAS 405 UL	NEXT	902

BUILDING ZONE CONTROL PANEL

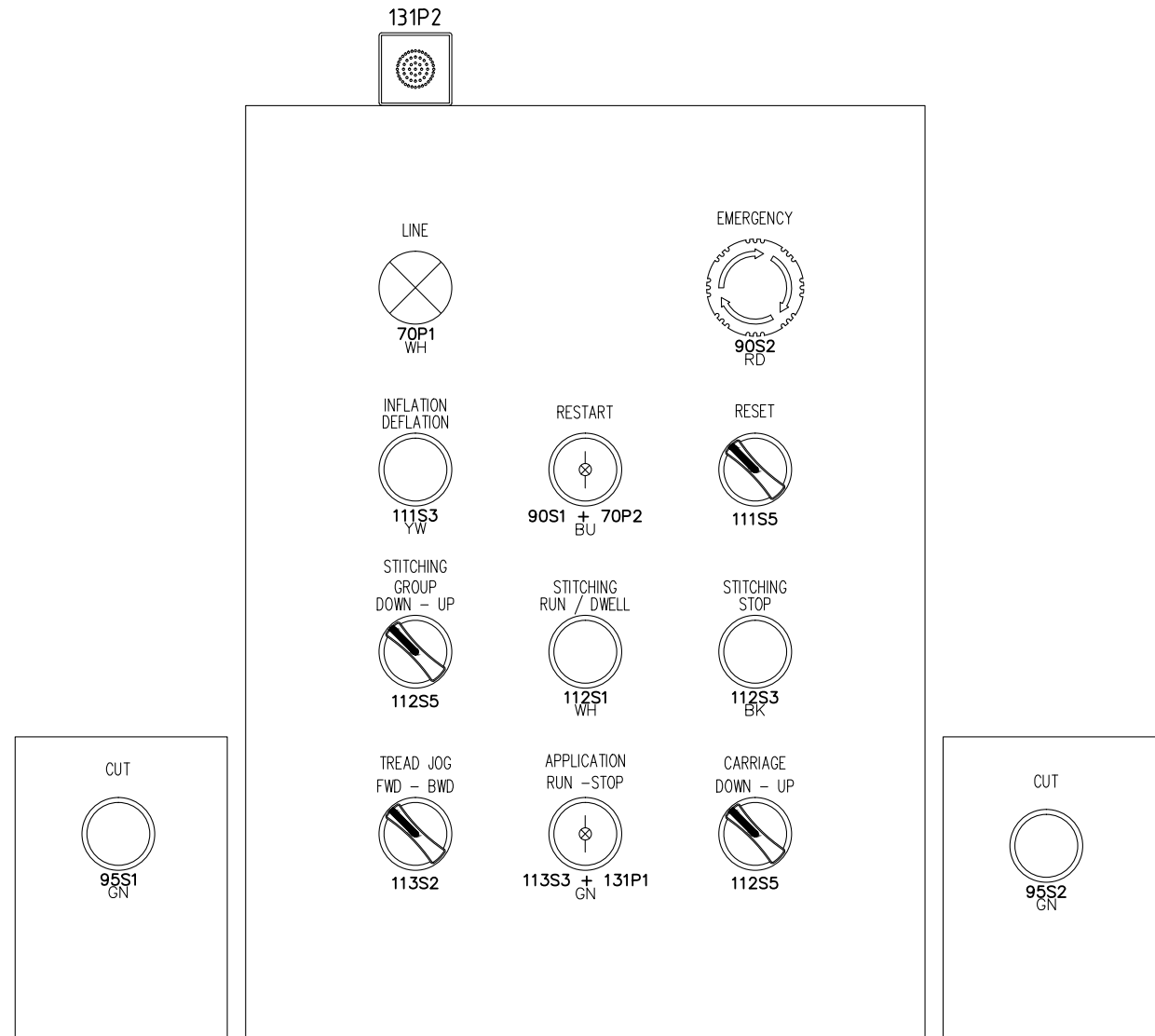

POLY ZONE CONTROL PANEL

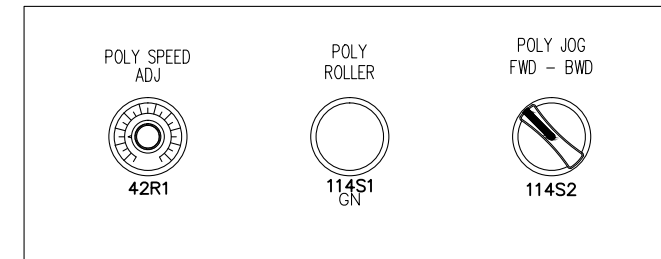

STITCHING ZONE CONTROL PANEL

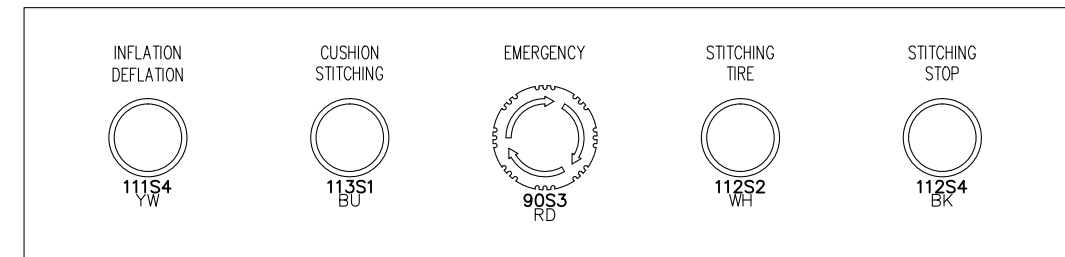

REV.	MODIFY	DATE	SIGN

Drawn	MATTEUZZI	Job	MEC 5693.1
Verified	MATTEUZZI	File Name	5693_1
Customer	MATTEUZZI	Date	16/07/2020

Title	PANNELLO COMANDI CONTROL PANEL LAYOUT	SHEET	902
Plant	TERMINALS AND LAYOUT RAS 405 UL	NEXT	/

*lista dei componenti e
schema pneumatico*

*pneumatic part list
and diagram*

*description des composants
et schéma pneumatique*

*Pneumatikteile-Liste und
pneumatischer Schaltplan*

*lista de los componentes y
esquema neumático*

SCHEMA PNEUMATICO – PNEUMATIC DIAGRAM
SCHEMA PNEUMATIQUE – PNEUMATISCHER SCHALTPLAN
ESQUEMA NEUMÁTICO

6598 - 05

COMPRESSED AIR

TYRE INFLATION

HUB INFLATION

POLY PINCH ROLLER

TREAD PRESSER

STITCHING TWIN ROLLER

STITCHING GROUP

TREAD LIFT

**SCHEMA PNEUMATICO – PNEUMATIC DIAGRAM
SCHEMA PNEUMATIQUE – PNEUMATISCHER SCHALTPLAN
ESQUEMA NEUMÁTICO**

6598 - 05

COMPRESSED AIR			
rif. ref. rep.	Descrizione – Description – Beschreibung – Descripción		Q.tà Q.ty Q.tè Cant. Menge
VL	27849.0	LOCKABLE VALVE, 1/2" NORGREN T73T-4GA-P1N	1
FR1	27305.0	FILTER REGULATOR, NORGREN 1/2" B73G-4GK-SP3-RMN	1
	29495.0	CLAMP c/with BRACKET, NORGREN 4314-52	1
G6	23226.0	PRESSURE GAUGE, 50 1/8" POS. 0-12	1
G6A	27364.0	PRESSURE GAUGE, D.63 1/4" POS.0-12 BAR CM063S12I	1
-	27743.0	TERMINAL FOR SOLENOID VALVE, KUHNKE L62518	2
VU	22932.0	ONE-WAY VALVE, 1/2"	1

TYRE INFLATION			
rif. ref. rep.	Descrizione – Description – Beschreibung – Descripción		Q.tà Q.ty Q.tè Cant. Menge
R2	24604.0	REGULATOR 3/8", STAMPOTECNICA 0-4BAR	1
G2	27363.0	PRESSURE GAUGE, D.50 1/4" POS.0-4 BAR M3F-50	1
EV2	27264.0	SOLENOID VALVE, NORGREN 3/2 V62C423A-A2000	1
YV2	26748.0	COIL, NORGREN QM/48/13J/21 24V dcc	1
	21567.0	LED CONNECTOR, 10/50V.	1
CK1	20646.2	SAFETY VALVE, 1/4" 2,5 bar	1
QE1	22255.0	QUICK EXHAUST VALVE, ART. VSR 1/2"	1

**SCHEMA PNEUMATICO – PNEUMATIC DIAGRAM
SCHEMA PNEUMATIQUE – PNEUMATISCHER SCHALTPLAN
ESQUEMA NEUMÁTICO**

6598 - 05

HUB INFLATION			
rif. ref. rep.	Descrizione – Description – Beschreibung – Descripción		Q.tà Q.ty Q.tè Cant. Menge
EV1	31613.0	SOLENOID VALVE, NORGREN 5/2 SXE9573-A71-00	1
	27742.0	BASE, KUHNKE L78782	1
YV1	26748.0	COIL, NORGREN QM/48/13J/21 24V dcc	1
	21567.0	LED CONNECTOR, 10/50V.	1
G5	24442.0	PRESSURE GAUGE, D.40 1/8" POS. 0-12 bar	1
R5	25776.0	PRESSURE REGULATOR, 1/4" with QUICK EXHAUST MR39 1/4" R8SRU	1

POLY PINCH ROLLER			
rif. ref. rep.	Descrizione – Description – Beschreibung – Descripción		Q.tà Q.ty Q.tè Cant. Menge
EV7	31613.0	SOLENOID VALVE, NORGREN 5/2 SXE9573-A71-00	1
	27742.0	BASE, KUHNKE L78782	1
YV7	26748.0	COIL, NORGREN QM/48/13J/21 24V dcc	1
	21567.0	LED CONNECTOR, 10/50V.	1
G7	25461.0	PRESSURE GAUGE, D.40 1/8" POS. 0-6 bar	1
R7	25776.0	PRESSURE REGULATOR, 1/4" w/QUICK EXHAUST MR39 1/4" R8SRU	1
C5	29050.0	CYLINDER, ISO FESTO D. 32X50 DNCB-32-50 PPV-A ART. 532726	1
	23184.0	FORK, ISO M10X1,25	1
	23183.0	HINGE, FEM. NORGREN D.32 QA/8032/ 23	1
F7/F8	20446.0	FLOW REGULATOR FOR CYLINDER, 1/8" DIA. 8 HOSE (458080)	2

SCHEMA PNEUMATICO – PNEUMATIC DIAGRAM
SCHEMA PNEUMATIQUE – PNEUMATISCHER SCHALTPLAN
ESQUEMA NEUMÁTICO

6598 - 05

TREAD PRESSER			
rif. ref. rep.	Descrizione – Description – Beschreibung – Descripción		Q.tà Q.ty Q.tè Cant. Menge
EV6	31613.0	SOLENOID VALVE, NORGREN 5/2 SXE9573-A71-00	1
	27742.0	BASE, KUHNKE L78782	1
YV6	26748.0	COIL, NORGREN QM/48/13J/21 24V dcc	1
	21567.0	LED CONNECTOR, 10/50V.	1
G3	25461.0	PRESSURE GAUGE w/BRACKET, D.40 1/8" POS. 0-6 bar	1
R3	25776.0	PRESSURE REGULATOR, 1/4" w/QUICK EXHAUST MR39 1/4" R8SRU	1
C3	30558.0	CYLINDER, ISO FESTO D.40X25 DNCB-40-25-PPV-A ART.532737	1
	27376.0	HINGE, MALE NORGREN D.40 QA/8040/27	1
F5/F6	20437.0	FLOW REGULATOR FOR CYLINDER, MALE 1/4"-D8	2

STITCHING TWIN ROLLER			
rif. ref. rep.	Descrizione – Description – Beschreibung – Descripción		Q.tà Q.ty Q.tè Cant. Menge
EV5	31613.0	SOLENOID VALVE, NORGREN 5/2 SXE9573-A71-00	1
	27742.0	BASE, KUHNKE L78782	1
YV5	26748.0	COIL, NORGREN QM/48/13J/21 24V dcc	1
	21567.0	LED CONNECTOR, 10/50V.	1
G4	25461.0	PRESSURE GAUGE, D.40 1/8" POS. 0-6 bar	1
R4	25776.0	PRESSURE REGULATOR, 1/4" w/QUICK EXHAUST MR39 1/4" R8SRU	1
C2S	29051.0	CYLINDER, COMPACT FESTO D.40X80 ADN-40-80-IPA ART.536308	1
C2D	29051.0	CYLINDER, COMPACT FESTO D.40X80 ADN-40-80-IPA ART.536308	1

**SCHEMA PNEUMATICO – PNEUMATIC DIAGRAM
SCHEMA PNEUMATIQUE – PNEUMATISCHER SCHALTPLAN
ESQUEMA NEUMÁTICO**

6598 - 05

STITCHING GROUP			
rif. ref. rep.	Descrizione – Description – Beschreibung – Descripción		Q.tà Q.ty Q.tè Cant. Menge
EV3/4	27365.0	SOLENOID VALVE, NORGREN 5/3 CC SXE9673-A60-00/000	1
	27742.0	BASE, KUHNKE L78782	1
YV3	26748.0	COIL, NORGREN QM/48/13J/21 24V dcc	1
	21567.0	LED CONNECTOR, 10/50V.	1
YV4	26748.0	COIL, NORGREN QM/48/13J/21 24V dcc	1
	21567.0	LED CONNECTOR, 10/50V.	1
G1	25461.0	PRESSURE GAUGE, D.40 1/8" POS. 0-6 bar	1
R1	25776.0	PRESSURE REGULATOR 1/4" w/QUICK EXHAUST MR39 1/4" R8SRU	1
C1	29049.0	CYLINDER, ISO FESTO D.80X150 DNCB-80 150-PPV-A ART. 532726	1
	23712.0	HINGE, MALE NORGREN D.80 QA/808 0/27	1
F1/F2	22146.0	FLOW REGULATOR, 3/8" DIA. 8 HOSE (453080)	2
URG	20525.0	FLOW REGULATOR, 1/4" ART. 6000	1
VSR	20655.0	FLOW REGULATOR,	1

TREAD LIFT			
rif. ref. rep.	Descrizione – Description – Beschreibung – Descripción		Q.tà Q.ty Q.tè Cant. Menge
VM	20538.0	PNEUMATIC CONTROL, 1/8" 4001 I	1
C4	30799.0	CYLINDER, ISO FESTO D.63X900 DSBC-63-900-PPVA-N3 ART.1463483	1
	23179.0	CLEVIS, ISO M16X1,5	1
	23180.0	PIN FOR CLEVIS ISO M16X1,5	1
	30593.0	KIT W/OSCILLATING PIN, FESTO ZNCM-63 ART .163528	1
F3/F4	22146.0	FLOW REGULATOR FOR CYLINDER, 3/8" DIA. 8 HOSE (453080)	2

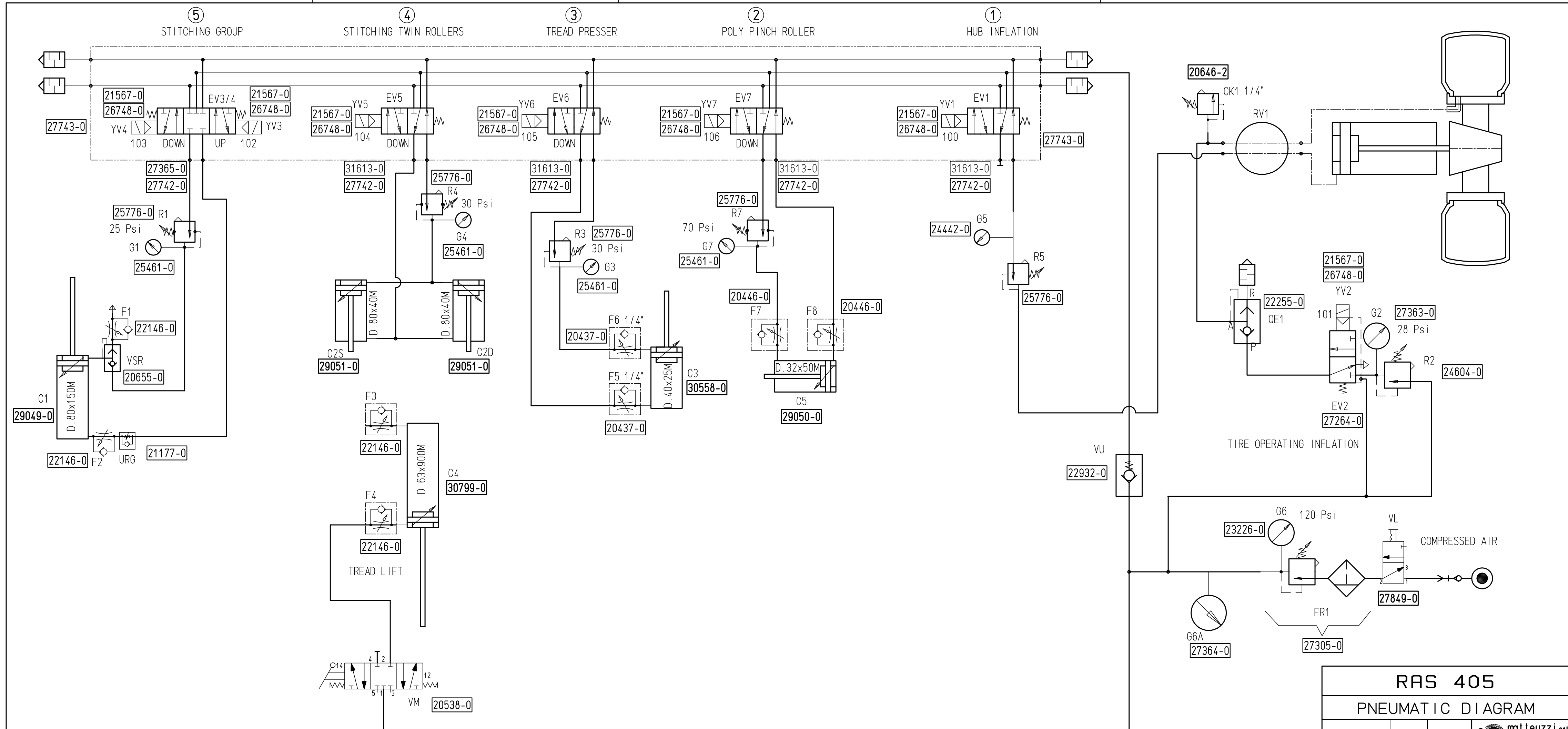

RAS 405 BUILDER

**PRECURED TREAD BUILDING AND STITCHING MACHINE
FOR TRUCK TYRES**

ANNEXES 1, 2, 3

to OPERATION AND MAINTENANCE MANUAL



**MACCHINE PER PNEUMATICI E PER I PROCESSI DI RICOSTRUZIONE
EQUIPMENT FOR THE TYRE AND RETREADING INDUSTRIES**

matteuzzi srl
Via Serra 1/E - 3
40012 Calderara di Reno - Bologna - ITALY
Tel. +39 - 051726351
Fax +39 - 051726283
matteuzzi@matteuzzi-srl.com

www.matteuzzi-srl.com