

UNICIRCLE

ULTRA - Smart Version

PRECURED TREAD POSITIONING AND STITCHING MACHINE
for truck, bus and light truck tyre casings

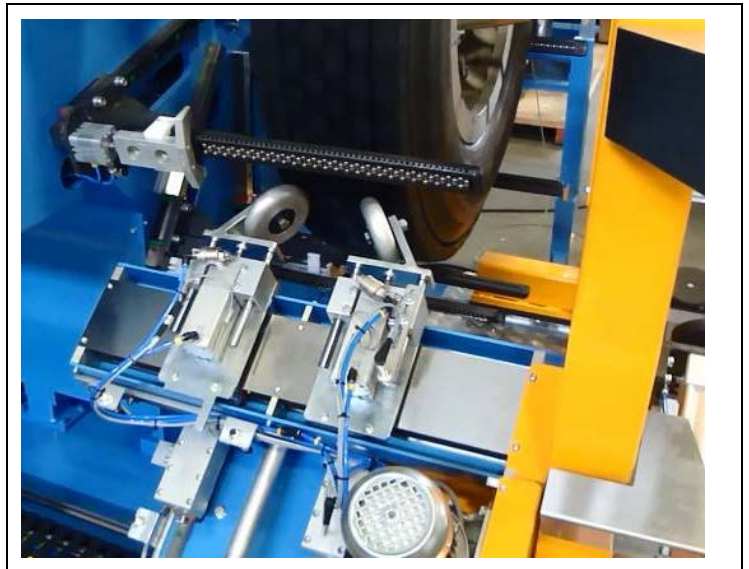

RING TREAD APPLIER has been designed to build and stitch precured tread rings on suitably prepared casings of truck, bus and light transport vehicle tyres.

GOODYEAR
Retreads

UNICIRCLE ULTRA – Smart Version for truck, bus and light truck tyre casings

Main features

Dimensions of the machine in service.

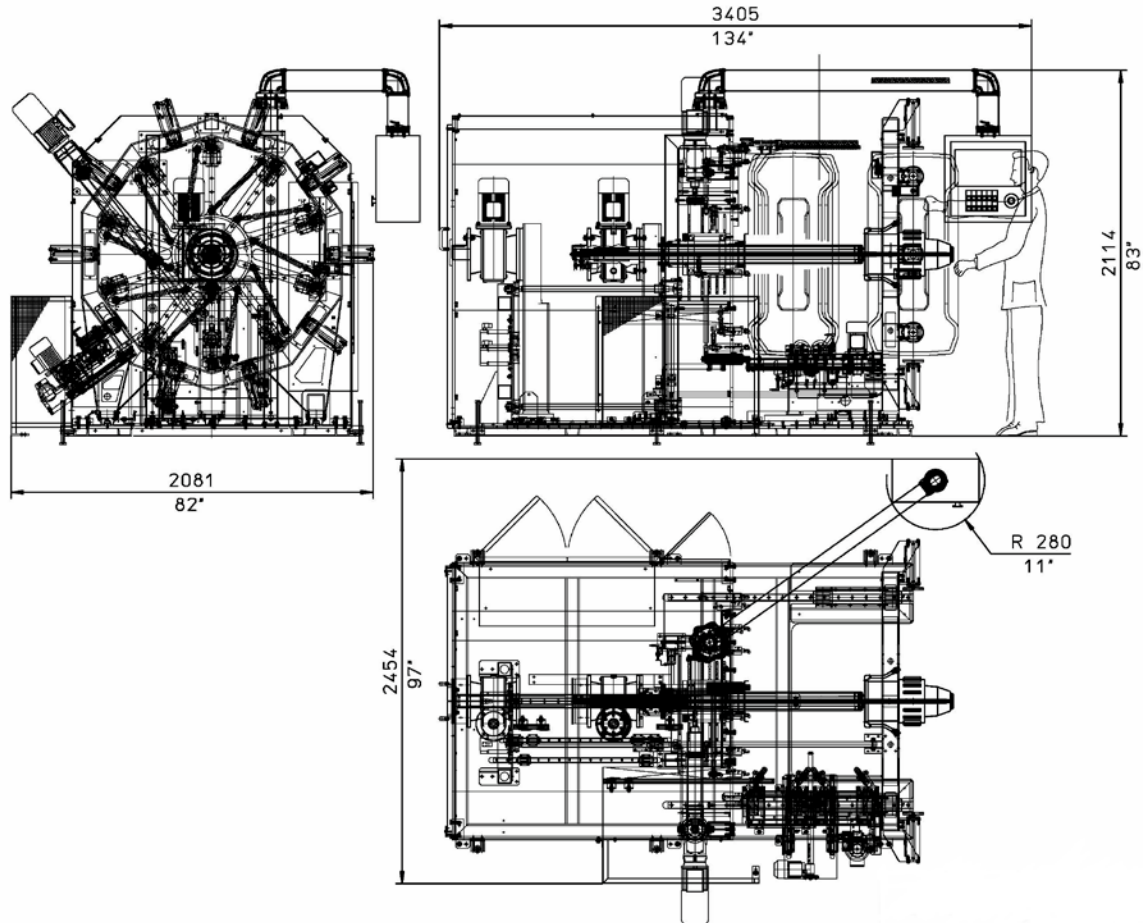

Net weight	2385 kg – 5366 lbs
Total installed power:	9 kW (12 hp)
Compressed air absorption:	490 NI/cycle - 15 cu ft/cycle

Max. buffed tyre casing diameter	47"	1190 mm
Min. buffed tyre casing diameter	26"	650 mm
Max. buffed tyre section	18"	445 mm
Max. tyre casing weight	225 lbs	100 kg
Max. precured tread width	17" 1/2	450 mm
min. precured tread width	6"	150 mm
Max. precured tread thickness	1¼"	32 mm