

# RETRAXX 6011

## CUSHION GUM EXTRUDER

### TECHNICAL DESCRIPTION



#### **Cushion Gum Extruder for pre-cured treads.**

- Computer controlled / Simple / Robust / Effective
- Saves cushion gum costs by using single size of feed strip
- Save cement spraying costs with correctly formulated cushion gum
- Save labor costs by automatic skive filling
- Optional: Manual Builder

## 1. Application

The RETRAXX type 6011 system extrudes a cushion gum layer and smears it directly onto the buffed tire casing in one rotation of the casing and simultaneously fills skive holes (buzz-outs).

The buffed tire casing is to be placed on the expendable rim and hub, is brought under pressure and moved towards the RETRAXX extruder head. A skilled operator needs to attend the process. After cushion gum layer application the tire can be directly removed and be further processed on a next station for tread application or the pre-cured tread can be manually applied whilst the tire is still on the RETRAXX 6011 hub.

The variable speed on the extruder drive, together with the adjustable hub speed, enables get the optimum in output for all tire sizes. This unit is provided with a display on eye level.



Cushion Gum Extrusion

The RETRAXX 6011 is available in the following versions:

- Automatic cushion gum application only
- Cushion gum application with manual builder (including automatic stitching)

## 2. Performance

The machine output is in the range of 190 to 240 tires per 8 hour shift.

The machine performance is an indication only and depends on tire size, cushion gum, skive volume and tread design. For smaller tire size the output can be higher. Please note that for larger tires the output can go down to 60% of the above mentioned figures because of higher cycle times.

## 3. Technical Data

Required feed strip size:	50 x 8 mm
Min casing diameter:	600 mm, buffed
Max casing diameter:	1370 mm, with tread applied
Extruded width:	140 to 420 mm
Extruded width with wings:	140 to 380 mm
Max tire weight:	140 Kg

## 4. Dimensions and Weight

Main dimension (L x W x H):	3238 x 1701 x 1922 mm
Weight:	1800 Kg
Mains supply:	400 V, AC, +/- 5%, 3 ph, 50 Hz 460 V, AC, +/- 5%, 3 ph, 60 Hz (USA)
Connecting power:	35 kW
Compressed air:	8 to 10 bar, filtered and oil-free
Water supply:	Clean water, 1/2". Max 25 °C; no chlorine, no distilled or ionized water , PH value 7-8
System colors:	Machine base Grey RAL 7035 Accents Blue RAL 5015

The system consists of the following modules:

### 4.1. Extruder Builder RETRAXX

- MCTD 60 extruder with variable speed 63-108 RPM, 11-20 kW AC drive;
- 12-segment expanding hub;
- Allen Bradley PLC and Allen Bradley touch screen control panel in the frame;
- Feed strip alarm;
- Alarm in case machine on standby too long in hot condition with cushion rubber inside;

### 4.2. Temperature Control Unit (TCU)

The unit controls the temperature through a water circuit passing successively the head, barrel en screw. The unit is integrated in the machine frame and is to be connected to a clean water supply or cold water circuit for cooling and to keep the water quantity in the unit on the right level. In case no clean water of maximum 25°C is available, the optional refrigeration unit (chiller) is strongly recommended.

### 4.3. Shoulder shaping

Included is one (1) set of standard blind covers, for simple pre-cure tread. An alternative customer specific geometry can be agreed upon. Optionally additional wing formers also for wing treads or contour treads are available.

## 5. Options

### 5.1. Manual builder

The machine can be equipped with a manual builder, adding a laser light to assist the operator in manually applying the tread and an automatic stitcher. The machine output for cushion gum extrusion and including manual builder is in the range of 96 to 120 tires per shift.

### 5.2. Refrigeration unit (Chiller)

Refrigeration unit with closed cold water circuit to cool the TCU's and to keep the water level in the TCU's on the right level. In case no clean water circuit/supply of maximum 25°C to the TCU's can be assured, this option is strongly recommended. Due to the larger tank capacity, the regular topping up with clean and pretreated water can be done at a low level warning. The refrigeration unit is placed next to the machine.

### 5.3. Temperature control unit

Additional temperature control unit for a separate temperature zone for the head. For sensitive cushion gum compounds it can be desirable or necessary to split the temperature control of the temperature control of the head from the barrel. The second unit is placed next to the machine.

### 5.4. Air conditioning

Air-conditioned electrical cabinet for ambient temperatures above 35 °C

### 5.5. Wide head

For retreading shops that have to deal with Super Single tires. Instead of the standard extruder head for up to 420mm extruded width, the machine can be shipped with a wider head, for up to 500mm extruded width.

### 5.6. Wing formers

Extra set of wing formers angled or contoured for building of shoulder run-out on the casing. Choice of various VMI standard geometries or an alternative customer specific geometry can be agreed upon.

- Angle wing formers: for pre-cure tread with "wings";
- Contour wing formers: for contoured pre-cure tread.

Please note the extruded width will be slightly reduced with the use of wing formers. For additional information refer to the separate attachment "RETRAXX wing formers".

### 5.7. Feedstrip guide rollers

Rollers to guide the feedstrip from the side of the machine to the extruder feed opening.

## 6. Technical Basis and Requirement at Customer

The system offered is subject to the following requirements unless otherwise specified:

- Ambient temperature range 5 °C to 35 °C;
- Relative humidity less than 80%;
- Altitude less than 1500 m;
- Dust and vibration free surroundings to European industry standards;
- All electrical, pneumatic and water supply and discharge lines to the equipment to be provided by customer;
- Foundation to industry norm.
- Technical execution to VMI technical and safety standards;
- VDE and CE safety standards are applied.

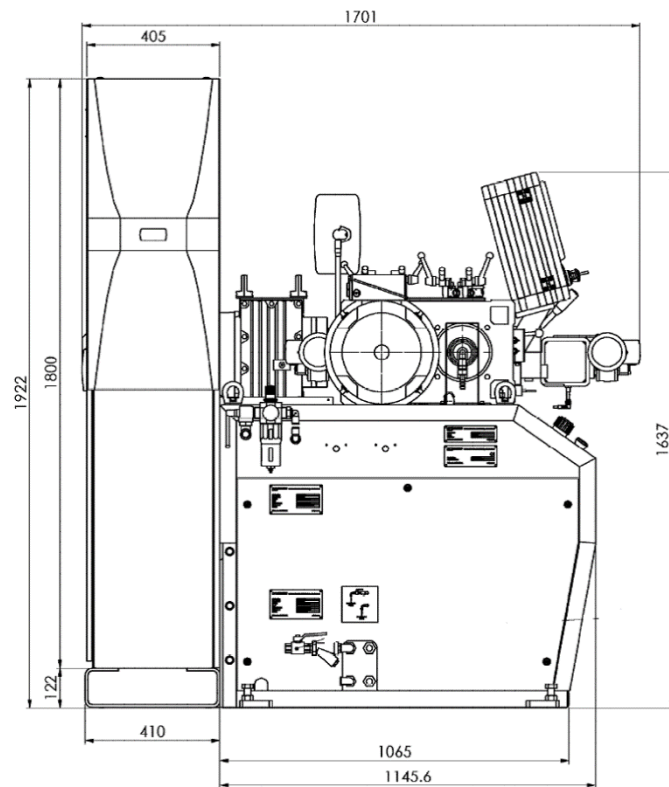
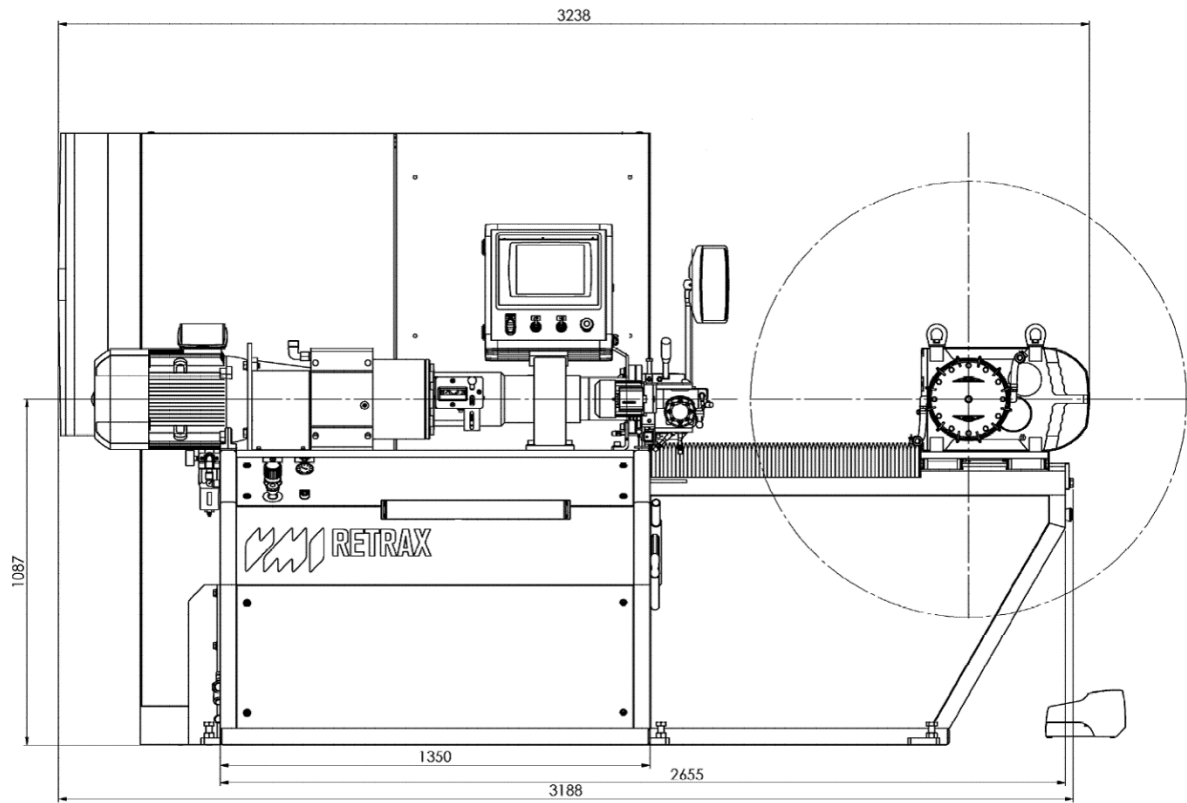

Front and Side view of RETRAXX 6011  
(Actual layout may slightly differ)